



# Supercal 5 I

## Instructions for Use

- Read this manual thoroughly before using the calculator.
- Be sure to read the “Safety” section (page 10) to ensure proper use of the calculator.
- After reading this manual, keep it easily accessible so that it is ready for future reference.

## Legal Provisions

The information contained in this document is the property of Sontex SA. Publication, in whole or in part, requires the written consent of Sontex SA. Any internal reproduction intended for evaluation of the product or its proper use is permitted and not subject to authorisation.

### Warranty

Please contact your local Sontex representative for warranty information.

### Trademark

M-Bus is a European standard (EN 13757-2/3) for reading heat meters.

Modbus® is a registered trademark of Schneider Electric and is licensed by the Modbus Organization, Inc.

BACnet® is a registered trademark of the American Society of Heating, Refrigerating and Air-Conditioning Engineers (ASHRAE). Sontex SA is BACnet certified. The BACnet certificate is available at the following link:

<http://www.bacnetinternational.net/btl/index.php?m=269>



# Table of Contents

<b>1.</b>	<b>Notes on this Document</b>	<b>7</b>
1.1	Scope of Validity	7
1.2	Target Groups	7
1.3	Storage of Document	7
1.4	Further Information	7
1.5	Symbole	8
<b>2.</b>	<b>Safety</b>	<b>9</b>
2.1	Personnel Qualification	9
2.2	Intended Use	9
2.3	Safety Instructions	9
2.3.1	Occupational Safety	9
2.3.2	Operational safety	10
2.3.3	Product Safety	10
<b>3.</b>	<b>Description</b>	<b>11</b>
3.1	Identification	11
3.1.1	Front Panel	11
3.1.1	Scope of Delivery	13
3.3	Certificates and Approvals	13
3.3.1	CE-Symbol	13
<b>4.</b>	<b>Installation</b>	<b>14</b>
4.1	Acceptance of Goods	14
4.2	Transporting and Storing the Calculator	14
4.3	Checking the Scope of Deliver	14
4.4	Structure and Components of the Calculator	14
4.4.1	Calculator Cover	15
4.4.2	Calculator Lower Part	15
4.5	Dimensions	16
4.6	Mounting	16
4.6.1	Before Mounting	16
4.6.2	Wall Mounting	17
4.6.3	Top Hat Rail Mounting	18
4.7	Installation Instructions for Temperature Sensors	18
4.7.1	Installation of Temperature Sensors	19
4.7.2	Connection of 4-Wire Temperature Sensors	20
4.7.2.1	Wire Cable Sensor with 2-Wire Calculator	20
4.7.3	Installation Guidelines for Temperature Sensors According to EN1434	21
4.7.3.1	Compliance With the Operating Conditions According to MID for the Temperature Sensors	21
4.8	Installation Check	21
4.9	Supercal 5S Installation Considerations (including flowmeter)	22
4.9.1	Horizontal Mounting Position	22
<b>5.</b>	<b>Wiring</b>	<b>23</b>
5.1	Wiring Requirements	23
5.2	Opening the Calculator	23
5.3	Wiring	23
5.4	Power Supply at the Calculator	24
5.4.1	Power Supply Modules	24
5.5	Connecting Sensors	24
5.5.1	Pulse Input for Volume Counting	24

5.5.1.1	Technical Characteristics of the Pulse Input for Volume Counting	24
5.5.2	Two Additional Pulse Inputs	25
5.6	Connecting Outputs	25
5.6.1	Two Open-Collector Pulse Outputs	25
5.6.1.1	Technical Characteristics of the Two Open-Collector Pulse Outputs	26
5.7	M-Bus Communication	27
5.7.1	Timing M-Bus Communication	27
5.7.1.1	Technical Characteristics of embedded M-Bus	27
5.8	Radio Modules	28
5.8.1	Radio Telegram	28
5.9	Supercal 5S General Considerations (including flowmeter)	28
<b>6.</b>	<b>Operation</b>	<b>29</b>
6.1	General Navigation	29
6.2	Standard Display	29
6.3	Control Buttons	29
6.4	Menus	30
6.5	Commissioning	30
6.6	Main Menu	31
6.7	Overview Menu	34
6.8	Metrological Setup	34
6.9	Stored Data	37
6.10	Configuration	37
6.11	Service	40
6.12	Sealing	42
6.13	Nowa / Unicon	42
6.14	Save Operating Data	42
6.14.1	Data Backup	42
<b>7.</b>	<b>Commissioning</b>	<b>44</b>
7.1	Commissioning of the Supercal 5	44
7.1.1	Checking Date and Time	44
7.1.2	Flow Control	44
7.1.3	Checking the Temperatures	44
7.2	Uses	44
7.2.1	Flow Calculation	44
7.2.1.1	Reaction time and Accuracy of the Flow Calculation	45
7.3	Software Superprog Windows and Superprog Android.	45
7.3.1	Download the Superprog Windows and Superprog Andorid.	45
7.3.1.1	Solar and Refrigeration Systems	45
7.3.1.2	Tariff Functions and/or Status Message Signal	45
7.3.1.3	Power Supply	46
7.3.1.4	Error Output	46
<b>8.</b>	<b>Maintenance</b>	<b>46</b>
8.1	Cleaning	46
<b>9.</b>	<b>Troubleshooting</b>	<b>46</b>
9.1	General Troubleshooting Procedure	46
9.2	Fault Indication	46
9.3	Error Messages	47
9.3.1	Overview of Error Messages	47
9.4	Troubleshooting M-Bus	48
9.5	Troubleshooting MODBUS	48
<b>10.</b>	<b>Decommissioning</b>	<b>48</b>
10.1	Exchange and Return	48
10.2	Disposal	48
10.2.1	Disposal	48

<b>11.</b>	<b>Technical Information</b>	<b>49</b>
11.1	Calculator Supercal 5 I	49
11.2	Power Supplies	50
11.2.1	Mains Modules	50
11.2.2	Battery Modules	50
11.2.3	Estimating the Battery Life of an M-Bus Application	50
11.3	Measurement concept	50
11.4	Arithmetic Logic Unit	51
11.5	Flow Sensors	51
11.6	Flow Measurement	51
11.7	Flow Calculation	52
11.7.1	Calculation of the Flow Rate with Conventional Flow Sensors	52
11.7.2	Calculation of the Flow Rate with Fast Flow Sensors	52
11.8	Temperature Measurement	52
11.8.1	General Information	52
11.8.2	Permissible Errors and Limit Values	53
11.9	Energy Measurement	53
11.9.1	Error Limits	53
11.9.2	Cooling Energy	53
11.9.3	Refrigeration Energy – Combined Cold/Heat Meter	53
11.9.4	Insulation Regulations for Refrigeration Systems	54
11.10	Calibration and Measurement Data	54
11.11	Nowa	54
<b>12.</b>	<b>Notes on Project Planning</b>	<b>56</b>
12.1	Safety and Security	56
12.2	Local Regulations	56
12.3	Power Supply	56
12.4	Lightning protection	56
12.5	Bus Facilities	56
12.6	Refrigeration Plants	57
12.7	Assembly	57
12.8	Lead Sealing	57
12.9	Service and Repairs	57
12.10	Installation Information	57
12.11	Minimum Distances	57
<b>13.</b>	<b>Appendix</b>	<b>58</b>
13.1	Extra Information for Supercal 5 S	58
13.1.1	Cut off Function of the Superstatic 440	58
13.2	Pressure Loss Curve	59
13.3	Dimension fluidic oscillator Superstatic 440	60
13.4	Technical Data Flow sensor Superststic 440	62
13.5	Optional Communication Modules Overview	63
13.6	Software	63
<b>14.</b>	<b>Return of good Form</b>	<b>64</b>
<b>15.</b>	<b>Country List</b>	<b>65</b>
<b>16.</b>	<b>Declaration of Conformity</b>	<b>65</b>



# 1. Notes on this Document

This manual provides all the information required for the correct use of the equipment including: product identification, installation, commissioning, troubleshooting, maintenance and disposal.

## 1.1 Scope

This documentation refers to the Sontex Supercal® 5 I and Supercal® 5 S. Specific details for the Supercal 5 S are noted in the appropriate sections of the manual.

## 1.2 Audience

This document is intended for system operators and installers of the calculator or heat meter.











## 1.3 Accessibility of the Document

The system operator must ensure that this document is accessible to the responsible personnel at all times. If the original document is lost, an up-to-date version can be downloaded from our extranet (<https://extranet.sontex.ch/index/>).

## 1.4 Further Information

Links to further information can be found at [www.sontex.ch](http://www.sontex.ch).

## 1.5 Symbols

Symbol	Significance
	<b>DANGER!</b> Failure to observe these warnings leads to fatal or serious injury.
	<b>WARNING!</b> Failure to observe these warnings may lead to fatal or serious injury.
	<b>CAUTION!</b> Failure to observe these warnings may lead to moderate injury.
	<b>NOTICE!</b> Failure to observe these warnings may result in damage to property.
	<b>Reference</b> Information that is important for a specific topic or goal, but not safety relevant.
	<b>Documentation</b> Reference to other documentation.
	<b>Help</b> Help in case of problems.
	<b>Visual check</b> Check that the item is in order.
	<b>CE-Marking</b> The calculator meets the requirements of the European directives 2014/32/EU (MID) and RED 2014/53/EU.
	<b>Disposal</b> This symbol indicates that electrical and electronic equipment must be disposed of separately. Do not dispose of the calculator with household waste.



## 2. Safety

Safe operation of the calculator can only be guaranteed if the operating instructions have been read and the safety instructions contained therein have been observed.

Further information and data can be found in the product's catalogues and data sheets, through your local representative, or on the Sontex homepage at [www.sontex.ch](http://www.sontex.ch).

- All technical data are without guarantee.
- Technical changes may be made at any time.
- In case of doubt, the text of the **English** Instructions For Use applies.

### 2.1 Personnel Qualification

Personnel responsible for installation, commissioning, diagnosis and maintenance must:

- Be trained and qualified to perform these functions.
- Be authorized by the plant operator.
- Be familiar with the relevant standards and directives and with national regulations.
- Read and understand instructions and additional documentation as well the relevant certificates.
- Follow instructions and general conditions.
- Be trained in the handling of hazards and risks involved in the installation and operation of electrical devices and systems.

Operating personnel must also:

- Be instructed and authorized by the plant operator in the task requirements.
- Follow the instructions in this document.

### 2.2 Intended Use

Supercal 5 is an electronic device for recording energy flows in heating and cooling systems. It can be used universally in industry, district heating and building services engineering.

- The manufacturer is not liable for damage resulting from improper use. Modifications and changes to the device must not be made.
- The Supercal 5 may only be operated within the conditions specified on the front panel and in the technical specification.
- Seals may not be removed except by authorized persons. Country-specific and local regulations as well as the manufacturer's instructions must be observed. The manufacturer assumes no responsibility for changes to the data relevant for calibration and measurement if the factory seal has been broken.
- If several heat meters are used in one billing unit, the same device types and installation positions should be selected to ensure that heat consumption is measured as fairly as possible.
- If water based cooling liquids (Glycol) are used, then the Superstatic 440 flow sensor must be used (mechanical flow sensors cannot be used).

### 2.3 Safety Instructions

#### 2.3.1 Occupational Safety

When working on and with electronic devices:

- Wear the protective equipment required under national regulations.

## 2.3.2 Operational safety

### Risk of injury!

- Operate the device only when it is in a fault-free and safe condition.
- The operator is responsible for the trouble-free operation of the device.

### Modifications to the device

Unauthorized modifications to the device are not permitted and can lead to unforeseeable risks:

- If modifications are nevertheless necessary: Consult your local representative or Sontex SA.

### Repair

To ensure continued operational safety:

- Only carry out repairs to the electronic device if these are expressly permitted.
- Observe the national regulations concerning the repair of an electrical and electronic devices.
- Only use original Sontex spare parts and accessories.

### Environmental requirements

If the plastic housing of the Supercal 5 is permanently exposed to certain vapour-air mixtures, the housing may be damaged.

- Contact your Sontex sales office for assistance.
- For use in areas subject to approval: See the information on the nameplate.

## 2.3.3 Product Safety

The Supercal 5 has been built and tested in accordance with good, state of the art engineering practice to ensure it's safe operation; it left the factory in technically perfect condition..

It meets the general safety and legal requirements. It also conforms to the EC directives listed in the device-specific EC Declaration of Conformity. Sontex SA confirms this by affixing the CE mark.

## 3. Description

### 3.1 Identification

The calculator can be identified using the information on the front panel.

#### 3.1.1 Front Panel

The following data according to PTB/MID can be found on the front panel:

Data on the front panel			
Manufacturer or customer logo	Sontex		
Product designation	Supercal 5*		
CE marking	CE Myy** 1259		
Item number	SC5lxxxxx		
Serial number/Year	S/N xxxxxxxx		
QR Code			
Environment class according to OIML or EN 1434	C		
Electrical/Mechanical class according to OIML or EN 1434	E1/M1		
Protection class according to OIML or EN 1434	IP65		
Temperature range ( $\Theta$ )	1..200 °C		
Temperature difference ( $\Delta\Theta$ )	3..150 K		
Temperature range cooling ( $\Theta_K$ )	1..200 °C		
Temperature difference cooling ( $\Delta\Theta_K$ )	3..150 K		
Pulse factor	See Display		
Installation	See Display		
Resistor	Pt500		
Approval mark	Country specific		
Flowmeter parameter: qp, qi, qs, DN, PN.	See Display		
M-Bus Interface	EN 13757-2		
Standard optical interface	EN 60870-5		
Optional Radio Interfaces	Sontex radio 433 MHz	wM-Bus 868 MHz	No Radio
NFC Chip Location	NFC )))		
Sontex Address	Rue de la Gare 27, 2605 Sonceboz. Switzerland		

\* In case of Supercal 5 S is acquired, it is identified as 5 S.

\*\* According to production year.

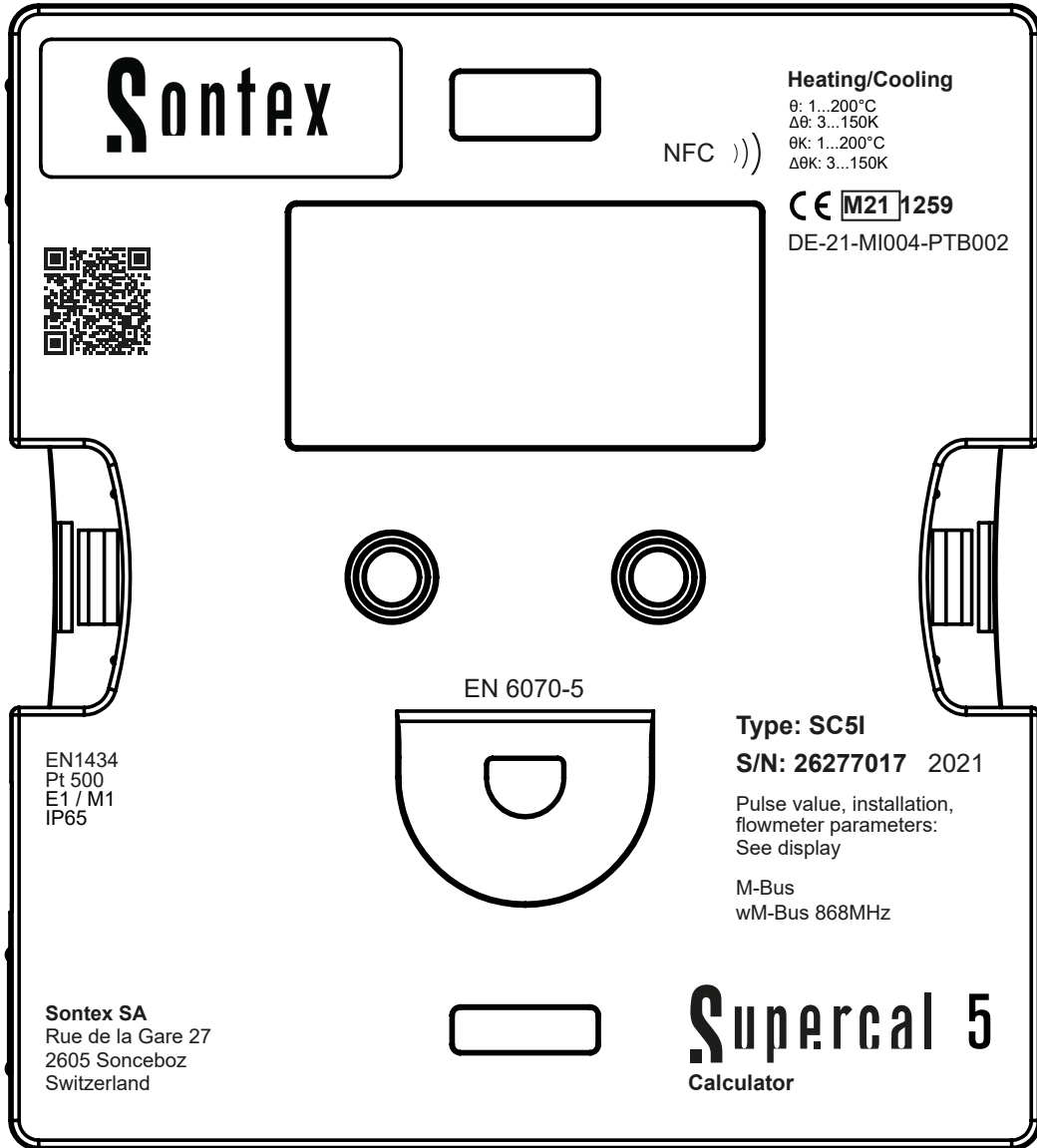

## 3.2 Scope of Delivery

The scope of delivery of the Supercal 5 includes:

- Installation guide
- Stickers (seals)
- Optional modules

## 3.3 Certificates and Approvals

The Supercal 5 and the optional pair of temperature sensors meet the requirements of Directive 2004/22/EC (L 135/1) (until 19.4.2016) or 2014/32/EU (L 96/149) (from 20.4.2016) (Measurement Instruments Directive, MID), as well as OIML R75 and EN-1434.

If the calculator and temperature sensors are to be used commercially, the flow sensor must also have a type approval (incl. conformity assessment) in accordance with MID.

### 3.3.1 CE-Symbol

The product meets the requirements of the harmonized European standards. Thus it meets the legal requirements of the EU directives. The manufacturer confirms the successful testing of the product by affixing the CE symbol.

## 4. Installation

Installation and commissioning of a heat measuring point should only be carried out by authorised, specialist personnel in compliance with the appropriate standards and local safety and installation regulations.

According to EN 1434-2 and EN 1434-6, the installation guidelines must be followed. A heat measuring point will only meet the planned accuracy and reliability requirements if these are complied with.

### 4.1 Acceptance of Goods

After receiving the goods, check:

- The packaging and contents are not damaged
  - The delivered product is complete
- Compare the scope of delivery with your order details.

### 4.2 Transporting and Storing the Calculator

The permissible ambient and storage conditions must be adhered to. Exact specifications can be found in the chapter Technical Information.

Observe the following points:

- For storage and transport the device must be protected against impact damage. The original packaging offers optimum protection for this.
- The permissible storage temperature is  $-25\dots+70^{\circ}\text{C}$ ; storage at the temperature limits should be limited to maximum 48 hours.

### 4.3 Checking the Scope of Delivery

Check the scope of delivery for completeness and possible damage. Contact your dealer or Sontex SA in case of faulty delivery.

### 4.4 Structure and Components of the Calculator

The Supercal 5 calculator consists of:

- A cover section, containing measurement and calibration components
- A lower, body section

The calculator's modular design allows for low storage costs and simple and effective meter replacement after the calibration validity has expired.

Only the cover section of the calculator needs to be replaced, the body section of the calculator, with all the mechanical connections (network, flow sensor, temperature sensor), remains in situ.

#### 4.4.1 Calculator Cover

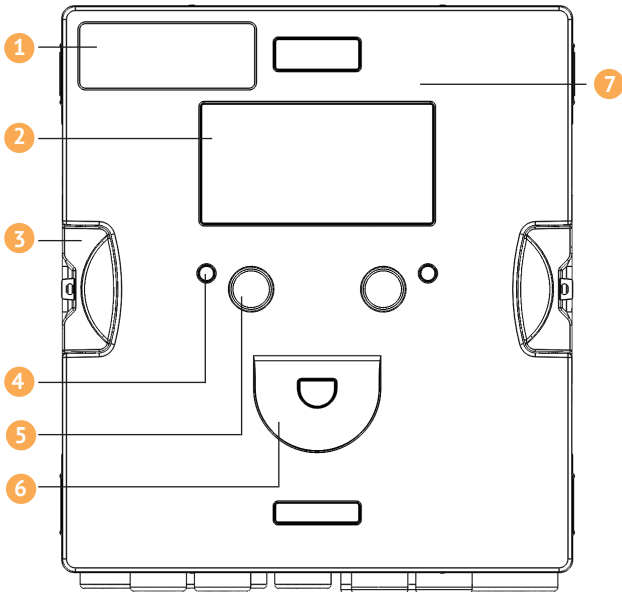

#### 4.4.2 Calculator Body

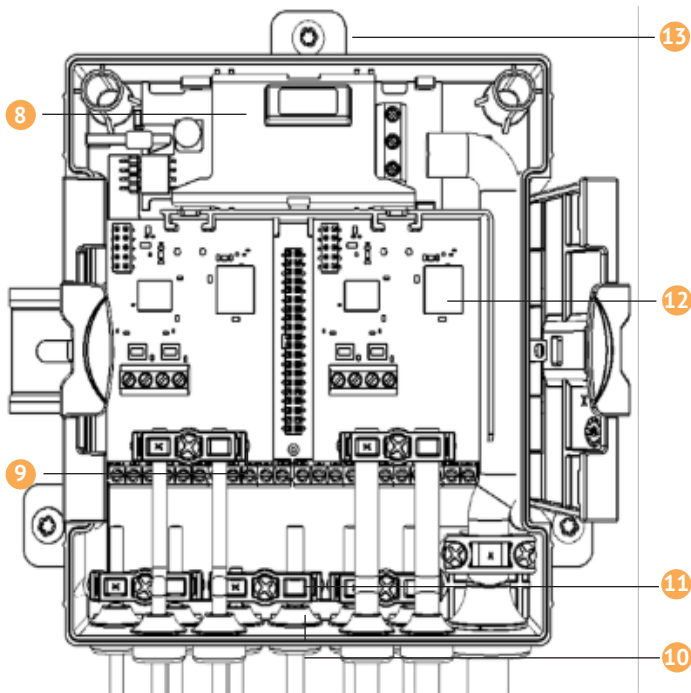

The following elements are located in cover and body part of the calculator:

- 1 Sontex or customer logo
- 2 Dot-Matrix Display
- 3 Brackets for Housing opening/closing
- 4 Two Status LED
- 5 Two operating buttons
- 6 Optical interface
- 7 NFC Interface
- 8 External mains / battery supply
- 9 Terminal block

- 10 Rubber gommets (IP65)
- 11 Strain reliefs for connection cable and earthing
- 12 Two slots for optional communication modules
- 13 Wall mounting sliders

## 4.5 Dimensions

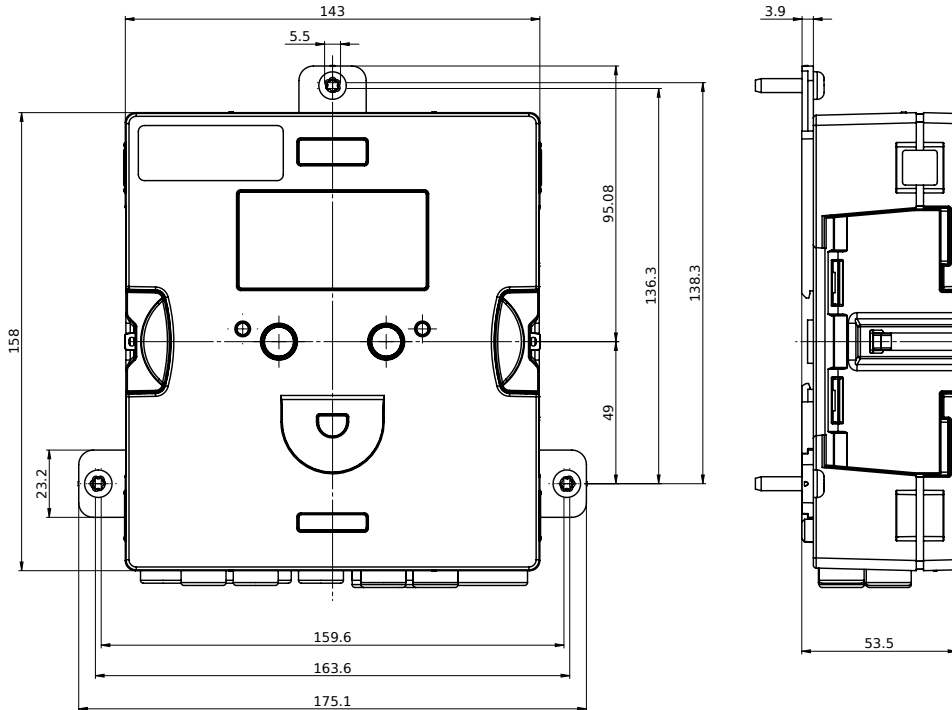

## 4.6 Mounting

### 4.6.1 Before Mounting



- All cables must be laid **at least 300 mm away from** power and high-frequency cables.
- Radiant heat and electrical interference fields in the vicinity of the calculator must be avoided.
- The calculator must generally be mounted away from the hot or cold pipes.
- Ensure no condensation can run into the calculator along the connected lines.
- If there is a risk of vibration in the piping system, the calculator should be mounted separately on the wall.
- For medium temperatures above 90 °C, the calculator should be mounted separately.
- The flow sensor should be mounted between two shut-off valves.
- The direction of flow in the flow sensor must be adhered to (arrow on the flow sensor).
- The pipeline must be flushed before mounting the flow sensor to ensure that there are no foreign bodies in the pipeline.
- The lines must be vented during commissioning. Air in the system or in the flow sensor can impair the measurement result.
- Only use suitable new sealing material.
- The tightness of the various connections must be checked.
- Lightning protection cannot be guaranteed; this must be ensured via the house installation.



Check the design data of the components.

- The flow sensor's pulse factor and location must correspond to the datasheet values; check the type plates!
- The permissible ambient temperature for the calculator is 5...55 °C.
- The installation and project planning regulations must be adhered to.
- The calculator faceplate and all nameplates must be legible.

The complete heat meter consists of the following three subunits:

- Flow sensor
- Calculator Supercal 5
- Temperature sensor (2- or 4-wire technology) with or without pockets

The pulse factor set in the calculator must match that of the flow sensor, the temperature sensor resistance set in the calculator must also match the temperature sensor.

The Supercal 5 calculator offers the following mounting options:

## 4.6.2 Wall Mounting

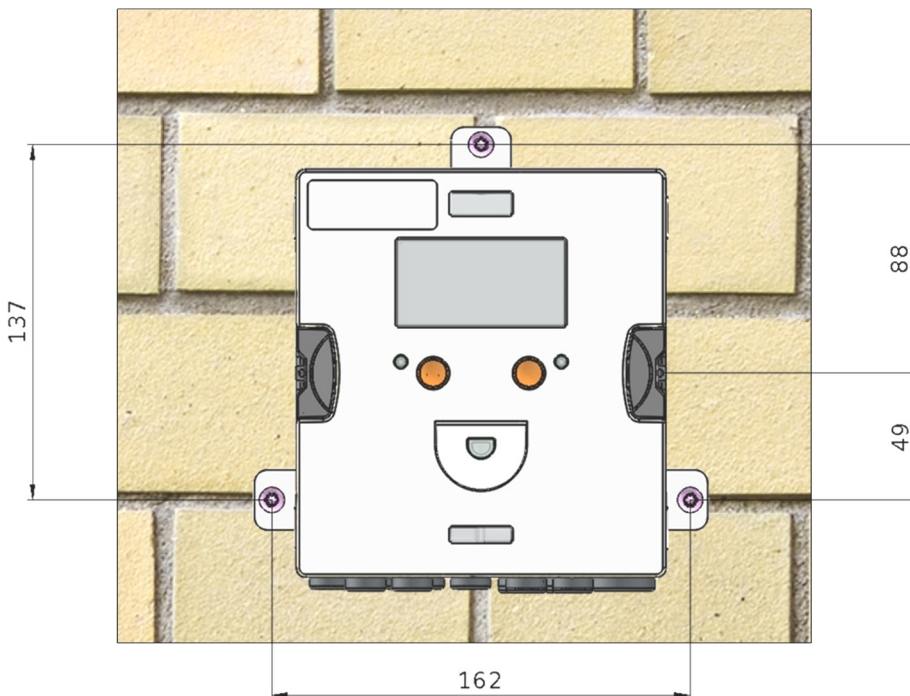

### 4.6.3 Top Hat Rail Mounting

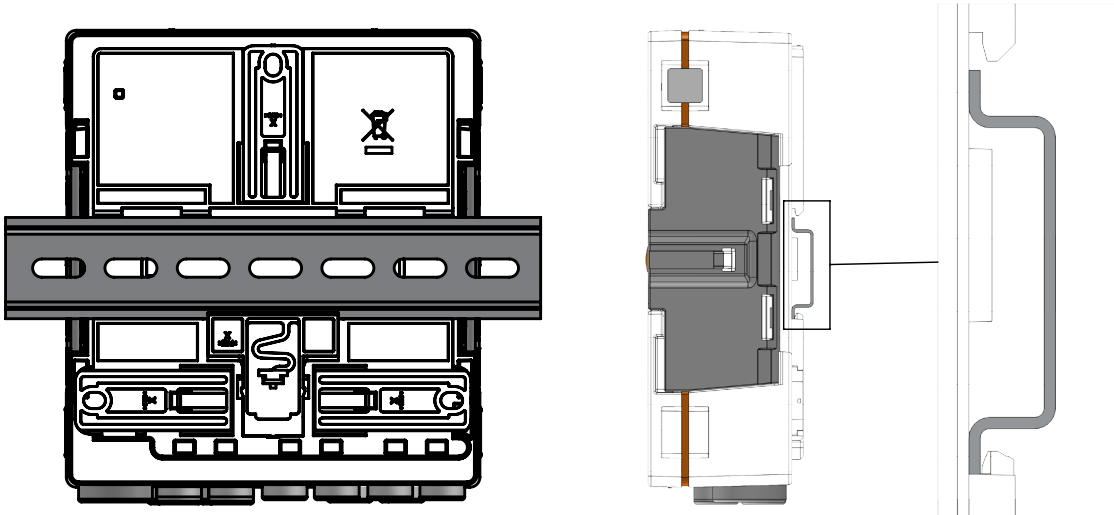

## 4.7 Installation Instructions for Temperature Sensors

Great care must be taken in selecting and installing temperature sensors. Errors made here cannot be compensated even by the best calculator.

### **CAUTION**

#### **Take care when installing the temperature sensors!**

Incorrect removal of directly immersed temperature sensors may result in an accident! Installation and removal may only be carried out by authorized and competent personnel.

### **NOTICE**

#### **Cables must be shielded against electromagnetic interference!**

If there is a risk of electrical or electromagnetic interference, temperature sensors in 2- and 4-wire technology with shielded cables or shielded cables must be used at the connection terminals. The shielding should be connected to the appropriate electrical ground in the calculator. Risk of interference increases with the length of the sensor cables!

#### **The connection cables must not be separated, extended or shortened!**

**The sensors are exactly computer paired in the factory and may only be used in the original pairs!**



#### **Installation with cable lengths over 3 m**

For installations with cable lengths over 3 m or with unequal cable lengths, we recommend the use of 4-wire temperature sensors. The maximum cable length of the 4-wire temperature sensors is 50 m

Only platinum temperature sensors with type approval in the Pt500 version are recommended. These must be paired and used in two-wire technology up to a cable length of 3 m. The connecting cables must not be separated, extended, or shortened.

For lengths of more than 3 m, we recommend the use of adequately shielded cable runs of equal length. The approval of the Supercal 5 allows 2-wire temperature sensors to be used up to a maximum length of 15 m and 4-wire temperature sensors up to a maximum cable length of 50 m. Supercal 5 can be used with a maximum cable length of 50 m.

The temperature sensors should preferably be installed directly and without pockets for low-temperature heating systems due to the minimum temperature spread. This allows even the smallest temperature differences to be determined without delays and heat dissipation errors.

In pipelines up to DN 150, temperature sensors may be installed directly or using pockets. The sensor tip should be located as close as possible to the middle of the pipeline.

Extensive information on the subject of temperature sensors can be found in our Sontex temperature sensor overview at: [www.sontex.ch/downloads/](http://www.sontex.ch/downloads/) under the heading temperature sensor 460.

### 4.7.1 Installation of Temperature Sensors

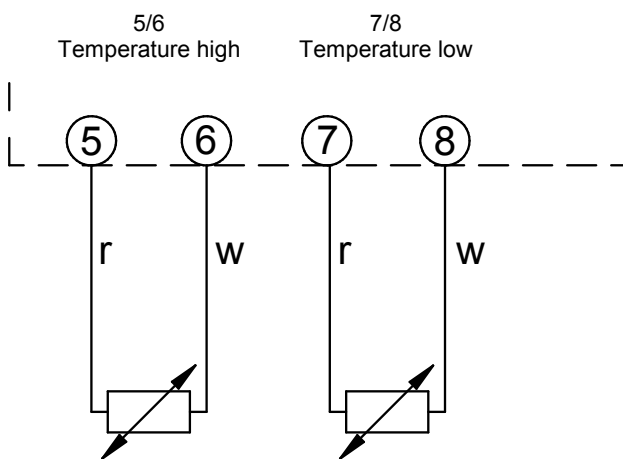

Since it is not the absolute temperature but the exact temperature difference that is important when measuring the heat quantity, both sensor cables must be of identical length (resistance). The sensors are very accurately computer paired in the factory and may only be used in the original pairs.

EN1434-2 2004 prescribes the following maximum cable lengths for 2-wire temperature sensors:

Wire cross-section	Maximum cable length
	<b>Pt500</b>
0,22 mm <sup>2</sup>	12,5 m
0,50 mm <sup>2</sup>	25,0 m
0,75 mm <sup>2</sup>	37,5 m
1,50 mm <sup>2</sup>	75,0 m

## 4.7.2 Connection of 4-Wire Temperature Sensors

For installations with cable lengths over 3 m or with unequal cable lengths, we recommend the use of 4-wire temperature sensors. The maximum cable length of the 4-wire temperature sensors is 50 m.

The connection cable must have four wires with a cross-section of at least 0,5 mm<sup>2</sup>

The insulation of the temperature sensor cables can be PVC or silicone. Sontex recommends the use of silicone insulation.

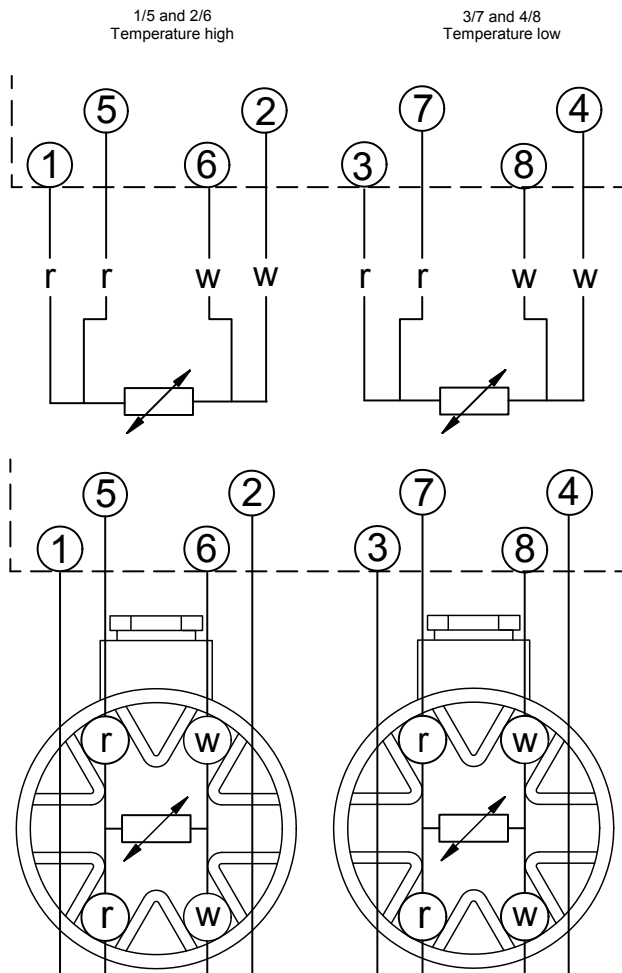

### 4.7.2.1 Wire Cable Sensor with 2-Wire Calculator

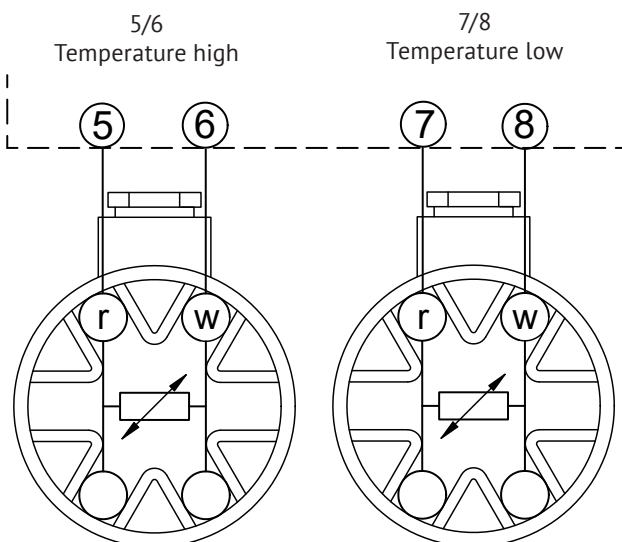

## 4.7.3 Installation Guidelines for Temperature Sensors According to EN1434

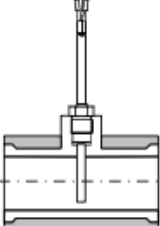
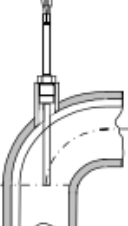
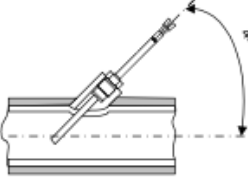
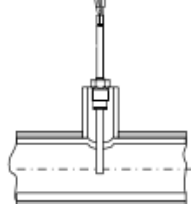
<p><b>DN15, 20, 25</b> Installation in T-fitting</p>  <p>Temperature sensor perpendicularly to the axis of the piping in the same level</p>	<p><b>≤ DN 50</b> Installation with welding sleeve 90°</p>  <p>Temperature sensor axle coincide with the tubing axle</p>	<p><b>≤ DN 50</b> Installation with welding sleeve 45°</p>  <p>Temperature sensor measuring element submerged onto the tubing axle</p>	<p><b>≤ DN 65 - 250</b> Installation in pipe</p>  <p>Temperature sensor axle perpendicularly to the tubing axle.</p>
--	---	--	---

### 4.7.3.1 Compliance With the Operating Conditions According to MID for the Temperature Sensors

The temperature sensors must be installed symmetrically in the flow and return pipes preferably directly. If temperature sensors are installed with pockets, both must be tested for conformity. The tips of the temperature sensors should sit cleanly on the thermowell bottoms. Installation points in the flow sensor can be used if the temperature sensors are installed symmetrically.

If the temperature sensors are permanently connected, the connecting cables must not be shortened.

Interchangeable temperature sensors with conformity markings allow a maximum length of 15 m with equal length for flow and return.

EN 1434-2 applies to the cable cross-sections. Care must also be taken to ensure that the calculator is electrically compatible with the temperature sensors:

- The calculator has been designed for Pt500 temperature sensors. Don't use other sensors.
- To prevent unauthorized access, the installation points must be sealed last.

## 4.8 Installation Check

For the installation of the heat meter and the associated temperature sensors, the general installation regulations according to EN 1434 Part 6 and the PTB Technical Guideline TR-K 9 must be adhered to. Guideline TR-K 9 is available for download on the PTB website.

After the shut-off valves have been opened, the installation must be checked for leaks. By repeatedly pressing the orange operating button, various operating parameters can be read on the LCD display of the calculator, e.g. flow rate, power, and flow and return temperature. The communication indicator on the LCD display can be used to check the communication input or output. The Superprog software can also be used to simulate communication outputs. The flow rate can be checked using the flow rate indicator. The dynamics of the flow sensor can be checked using the current flow display in conjunction with flow control.

All parameter displays are used to check the meter or to adjust the system. Check that the adjusted flow rate of the system does not exceed the maximum permitted flow rate of the meter. It is recommended that an installation protocol is made using the Android NFC tool or the optical interface with the Superprog software for complete functional testing.

## 4.9 Supercal 5S Installation Considerations (including flowmeter)

### Before installation

- Check the layout and design data of the installation.
- The calculator's pulse factor and the installation location settings must match the values indicated on the flow sensor - consult the identification plate!
- The permissible temperature operating range of the calculator is 5–55 °C.
- The installation and project provisions must be followed.
- The calculator faceplate and identification plates must be legible.
- The flow sensor should be mounted BEFORE any control valve to exclude any potential parasitic influences.
- During commissioning, the pipe system must be bled of air. Air in the flow sensor may affect the measurement.
- Use only new and appropriate sealing material.
- The watertightness of the different connections should be verified.
- Lightning protection has to be guaranteed by the house installation.



Straight sections of piping of 3 DN in flow and return of any flow meter or heat meter must be provided. For the Supercal 5 S up to DN 40 (qp10) straight sections of 3 DN are already included in the length of the flow sensor.

### 4.9.1 Horizontal Mounting Position

Sensor heads MUST be placed to the side +/- 45° of the pipe axis to avoid the influence of air (top) or dirt (bottom).

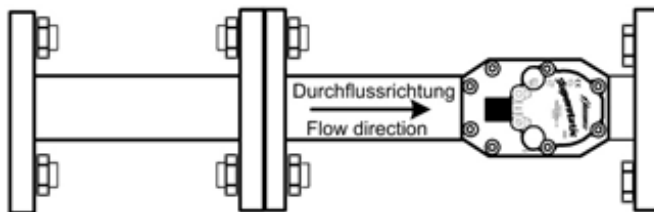

# 5. Wiring

## 5.1 Wiring Requirements

### **⚠ DANGER**

#### Danger due to electrical voltage!

- The entire electrical system must be voltage-free.

### **⚠ CAUTION**

#### Additional Electrical Information

- Before commissioning, ensure the supply voltage conforms to the information in the nameplate.
- Provide a suitable switch or circuit breaker in the building installation. This switch must be installed easily accessible near the device and marked as a disconnecting device.
- Overcurrent protection ( $\leq 10A$ ) must be installed in the mains cable.

For installing the heat meter and the associated subassemblies, the general regulations, according to EN1434-Part 6, must be observed.

## 5.2 Opening the Calculator

To connect the inputs and outputs, remove the calculator cover.

## 5.3 Wiring

Overview of the connections:

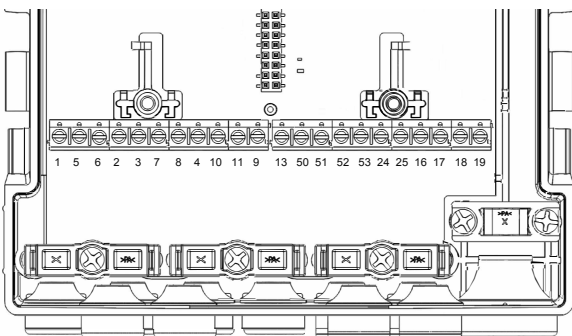

Terminal	Designation	Description
<b>Inputs</b>		
5, 6	2-wire technology	Temperature high
1, 5 and 6, 2	4-wire technology	
7, 8	2-wire technology	Temperature low
3, 7 and 4, 8	4-wire technology	
10	(+)	Pulse input flow sensor
11	(-)	
9	+Vdc	Power supply for flow sensor
50	(+) pulse input additional pulse input 1	Pulse inputs
51	(-) pulse input additional pulse input 1	
52	(+) pulse input additional pulse input 2	
53	(-) pulse input additional pulse input 2	
<b>Outputs</b>		
16	(+) open-collector output 1	Energy-, volume- or tariff counter
17	(-) open-collector outputs 1	
18	(+) open-collector output 2	
19	(-) open-collector output 2	
<b>M-Bus</b>		
24	M-Bus (polarity independent)	Embedded M-Bus
25	M-Bus (polarity independent)	

## 5.4 Power Supply at the Calculator

Supercal 5 can be supplied with either battery or external mains modules. These can be retrofitted at any time.

### 5.4.1 Power Supply Modules

The mains module is equipped with a backup battery already installed.

## 5.5 Connecting Sensors

### 5.5.1 Pulse Input for Volume Counting

The Supercal 5 allows the connection of slow and fast flow sensors. For this purpose, two specific filters are provided (normal or fast mode), which can be switched via the Superprog software.

#### 5.5.1.1 Technical Characteristics of the Pulse Input for Volume Counting

Designation	Description
Pulse Input	Terminal 10, flow meter 440 white cable
	Terminal 11, flow meter 440 green cable
Power supply flow sensor	Terminal 9 (3.7V..3.0V, max 1mA) the flow sensor 440 brown cable
Input frequency normal mode	Max. 5 Hz
Input frequency fast mode	Battery operation max. 200 Hz
Slow volume pulses	0,0001–99,999,999 l/Imp or Imp/l
Fast response volume electrical pulses	0,0001–99,999,999 l/Imp or Imp/l

#### Circuit Diagram Normal Mode

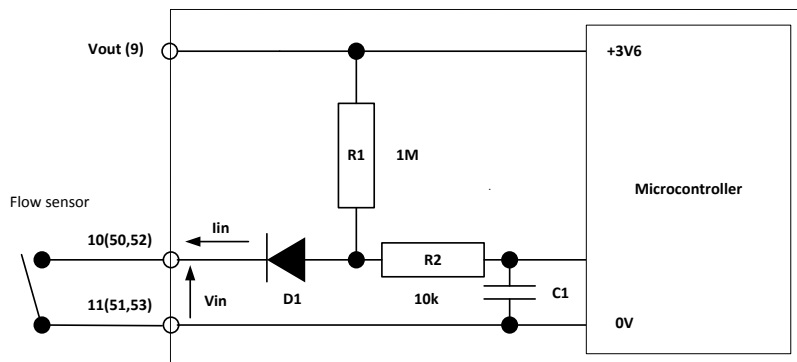

#### Circuit Diagram Fast Mode

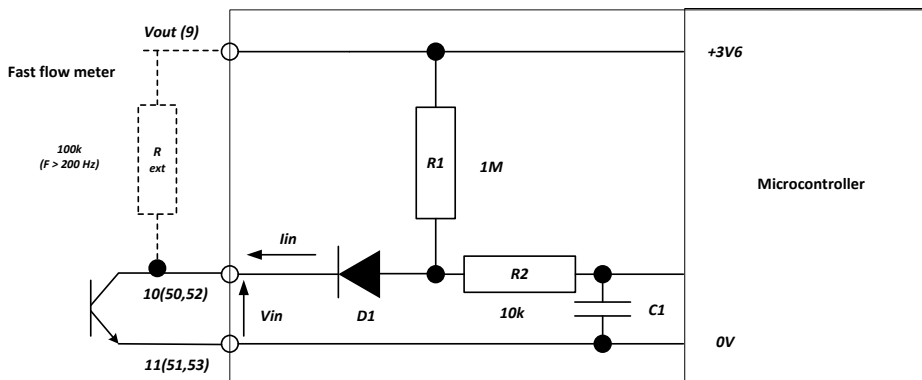

Terminal 9 is intended to supply a flow sensor up to  $V_{max} = 3.6V$  and  $I_{max} = 20\mu A$ . For higher voltage or higher current, it's strongly recommended to install a power supply module to avoid reduced battery lifetime.



## Electrical pulse diagram

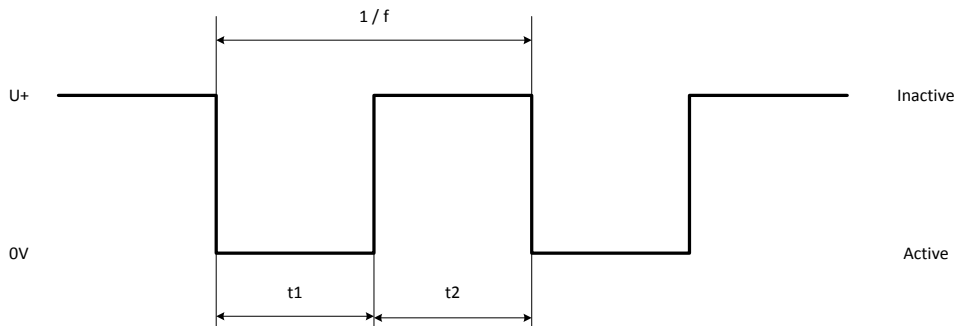

Designation	Description
Normal mode:	$t_1 = t_2$ min. 100 ms (with duty cycle = 50 %)
Fast mode (mains operation):	$t_1 = t_2$ min. 2,5 ms (with duty cycle = 50 %)
Vin max.	< 30V inactive, 0,5V active
Vin min.	2,0V inactive, 0V active
Iin max.	26 $\mu$ A inactive, < 100 $\mu$ A active
Iin min	0 $\mu$ A inactive, 1,4 $\mu$ A active

## 5.5.2 Auxiliary Inputs

The Supercal 5 has two additional pulse inputs (IN1 and IN2) for connecting additional counters for cumulative electrical pulse counting. These two auxiliary inputs are automatically integrated into the M-Bus, radio or optical telegram, and transmitted.

They enable the connection of various hot water, cold water, electricity, gas or oil meters. Their individual parameterisation (normal and/or fast mode) can be set-up in the software.

### Technical Characteristics of the Auxiliary Inputs

Designation	Description
2 inputs	IN1 at terminals 50/51
	IN2 at terminals 52/53
Input frequency normal mode	Max. 5 Hz
Input frequency fast mode	Battery operation max. 3,5 kHz
	Mains operation max. 12 kHz
Input voltage	0.. 30V
Slow volume pulses	0,0001–99,999,999 l/Imp or Imp/l
Fast volume pulses	0,0001–99,999,999 l/Imp or Imp/l

## 5.6 Connecting Outputs

### 5.6.1 Two Open Collector Pulse Outputs

Two open-collector outputs (OUT1 and OUT2) can be used to display energy, volume, tariff 1, tariff 2, alarm and threshold values.

The maximum current per output is 100 mA, the maximum voltage is 30V.

These parameters (in both normal or fast mode) can be set using the Superprog software.

Fast pulse outputs are used to control controllers, for example. The maximum pulse frequency here is 200Hz.

These outputs are not galvanically isolated. For the connection to control systems we recommend the use of relay outputs.

### 5.6.1.1 Technical Characteristics of the Two Open-Collector Pulse Outputs

designation	Description	Value
2 outputs	OUT1	at terminal 16/17
	OUT2	at terminal 18/19
Normal mode	Voltage	max. 30VDC
	Current	max. 100 mA
	Voltage drop	approx. 1,3V at 20 mA
	Duty cycle	1 : 1
	Electrical pulse duration	100 ms conductive
	Maximum electrical pulse frequency	5 Hz (+/- 20%)
Fast mode	Voltage	max. 30VDC
	Current	max. 100 mA
	Voltage drop	approx. 1,3V at 20 mA
	Pulse type	linear or scaled pulses
	Maximum electrical pulse frequency	200 Hz (+/- 20%)

#### Circuit diagram

Control of the outputs

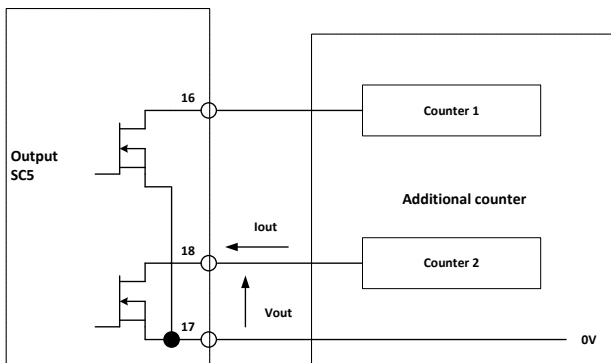

#### Pulse control

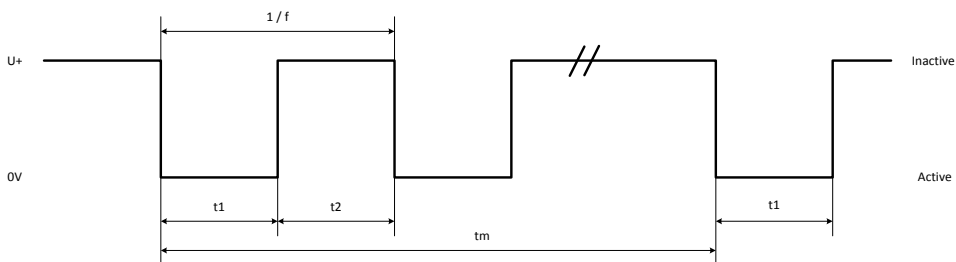

Designation	Description
Normal mode	$t_1 = t_2$ min. 100 ms (at duty cycle = 50%)
Fast mode (D battery or mains operation)	$t_1 = t_2$ min. 2,5 ms (at duty cycle = 50%)
Vout max.	< 30V inactive, 0,3V active
Vout min.	2,0V inactive, 0V active
Iout max.	< 5 $\mu$ A inactive at 30V, < 100 $\mu$ A active
Iout min.	0 $\mu$ A inactive, 1,65 $\mu$ A active at 3,6V

## 5.7 M-Bus Communication

M-Bus is embedded in the new Supercal 5 hardware. Up to two further communication modules can be added in the available slots. This ensures that up to three M-Bus requests for different applications can be processed and answered simultaneously. The two additional electrical pulse inputs are automatically integrated into the M-Bus telegram and transmitted. For unambiguous identification of the two electrical pulse inputs, one identification number and one fabrication number can be set respectively.

The Supercal 5 operates with a variable data structure. An individual primary address and baud rate can be set for each M-Bus output.

An M-Bus “application reset”, will set the factory settings according to standard EN 1434.

### 5.7.1 Timing M-Bus Communication

M-Bus interface : communication timings

According to EN13757-3 and EN1434-3

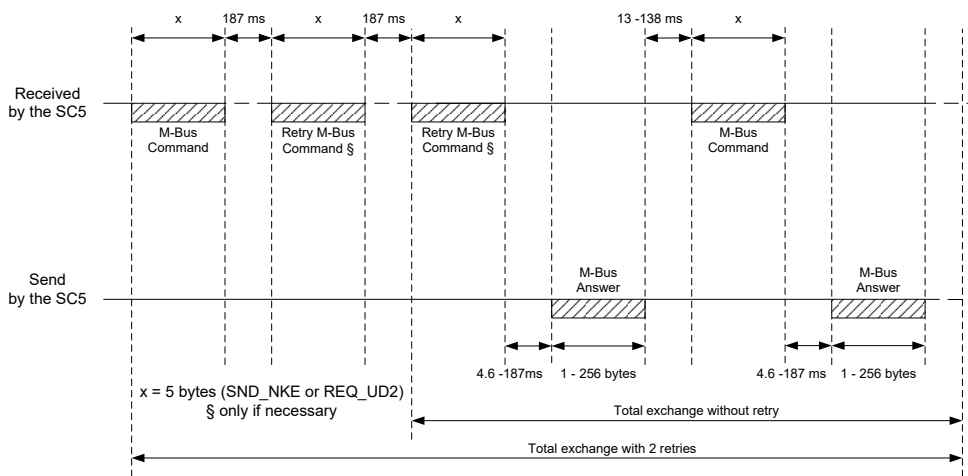

#### 5.7.1.1 Technical Characteristics of embedded M-Bus

Designation	Description
Interface definition	According to EN 1434-3
Interface	potential-free, reverse polarity protected
Transmission speed	300..9,600 baud (...4,800 baud with battery supply) selectable with Superprog Android & Superprog Windows.
Data structure	variable

Designation	Value
<b>Supply voltage</b>	
UMU,M (MARK)	36V
UMU,S (SPACE)	24V
UM,M (SPACE)	12V
UM,S (MARK)	11,3V
<b>Supply current</b>	
IM	1,5 mA
IS	20 mA

## 5.8 Radio Modules

Ex-factory the Supercal 5 can be configured with the following variants:

- Sontex Radio
- wM-Bus Radio
- No radio

<b>Sontex Radio</b>	<b>Description</b>
Proceedings	Bi-directional
Frequency	433.82 MHz
Transmitting power	≤ 10 mW
Range	Average 30 m, depending on the spatial and structural conditions
Available encryption	AES-128
<b>wM-Bus Radio</b>	
Proceedings	Uni-directional
Frequency	868 MHz
Transmitting power	≤ 10 mW
Range	1.000 m (Free Space)
Available encryption	AES-128

### 5.8.1 Radio Telegram

The Supercal 5 radio telegram is structured according to the M-Bus protocol according to EN1434-3.

The following telegrams are available for radio readout:

- Current values  
Cumulated values and current consumption values
- Monthly energy values  
Cumulated values and current consumption values  
60 default monthly energy values

## 5.9 Supercal 5S General Considerations (including flowmeter)

All shielded cables must be grounded and provided with strain relief!

It must be guaranteed that all ground connections (line and power, external mains and chassis of the flow sensor) of the entire installation are equipotential.

## 6. Operation

### NOTICE

- The safety and service marks relevant to calibration must not be damaged or removed. Otherwise the warranty of the device is void. User seals may only be removed by authorized persons for service purposes and must then be renewed.
- Once the optional module has been installed, the Supercal 5 calculator must be protected against unauthorised access with user seals.

### 6.1 General Navigation

The menus can be accessed from the standard display using the control buttons. The Supercal 5 has the following menus (press LEFT and RIGHT buttons at the same time)

1. Main Menu (data relevant for billing)
2. Metrological
3. Configuration
4. Service

The first time you power on the display, or after 3 minutes of inactivity you will see the Error menu if any error event occurred. If there were no errors, the screen will display the “Cumulated Energy” menu. This menu is the first one embedded into the Main Menu.

### 6.2 Standard Display

Large and clear LCD display for manual reading. The LCD display is structured as follows:

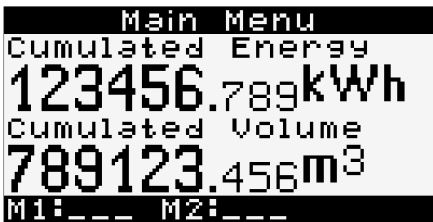

► Menu's name

► M1: Module installed in slot 1

► M2: Module installed in slot 2



#### Note

- After 3 minutes, the calculator display automatically switches back to the main menu.

### 6.3 Control Buttons

The control key can be used to select and confirm the various menus, parameters or other selection options within the display.

#### → Right Key

The Right key has two functions:

- A single press selects next.
- A two second press in the “Overview Menu” selects the highlighted menu.

#### ← Left Key

- Left key selects previous.
- With any menu highlighted, pressing both the LEFT and RIGHT keys for two seconds, will select the “Overview Menu”.

## 6.4 Menus

Six menus are available. The **Overview menu** is used to select the operational menus: **Main**, **Metrological**, **Configuration**, **Service** and **Commissioning**.

The **Commissioning menu** is only available when the calculator is used for the first time, or when the calculator is manually “unsealed”.



### Notes

- The error message in the main menu only appears if an error is present. The sum of the error codes is displayed. The content corresponds to the value of the error message parameter in the “Service” menu.

## 6.5 Commissioning

Once the Supercal 5 is unsealed, the Commissioning Menu is available in the Main Menu.

This setup menu allows the customer to configure the calculator via NFC. Other, non-metrological settings can always be changed using a smartphone via NFC or by using the Superprog and an optical interface.

After setup by NFC employing Superprog Android is completed, the Supercal 5 has to be sealed.

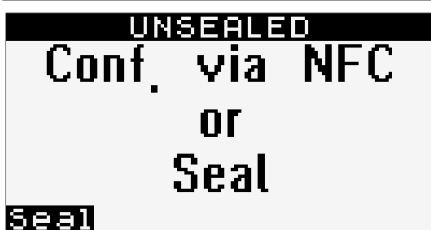

- Commissioning: commissioning menu
- Configuration via NFC

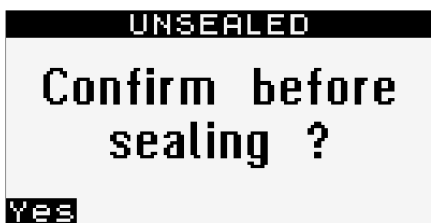

- 1 × short press on the left button
- Seal configuration
- SEAL: seals the configuration and switches to **Default Menu**

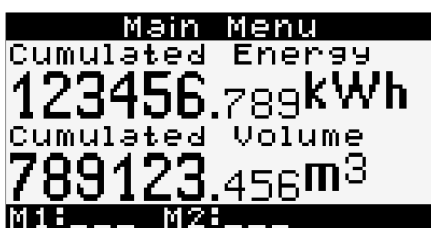

- 1 × long press on the left button (> 2 seconds)
- Cumulated energy
- Cumulated volume

Now the Supercal 5 is ready for use.

## 6.6 Main Menu

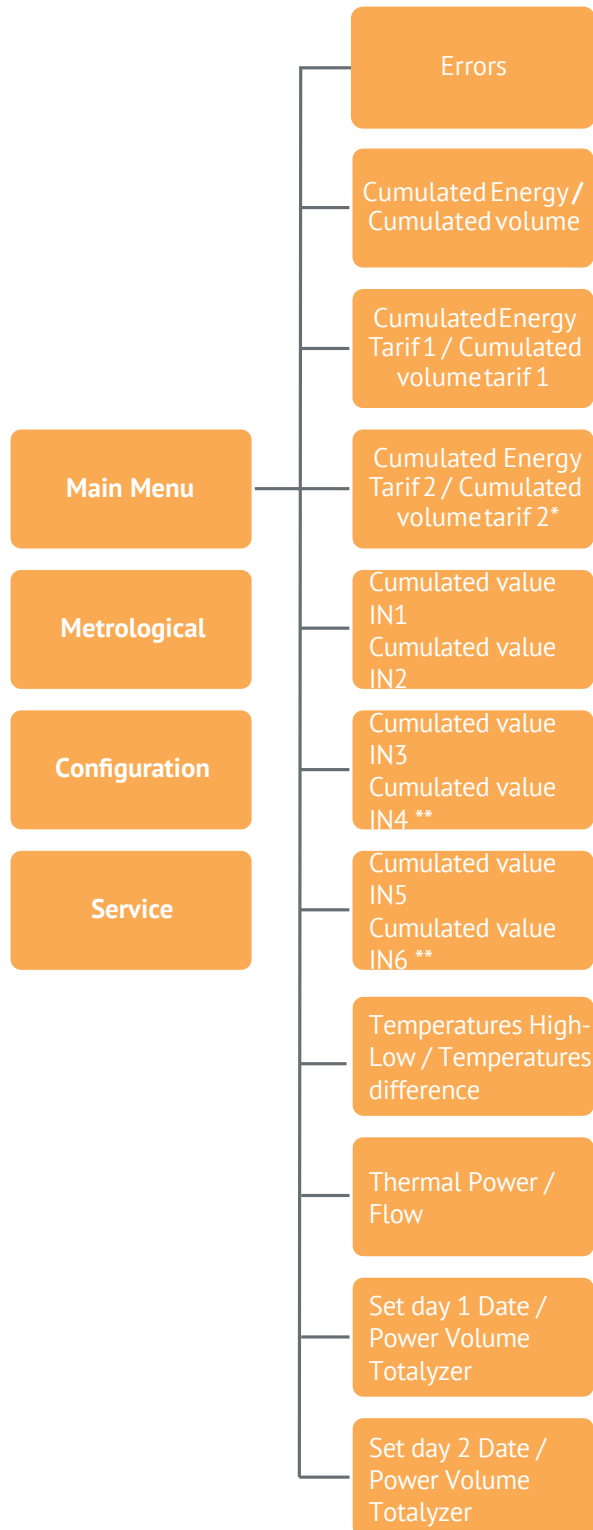

\* Active only in Heating/Cooling mode & Cooling mode

\*\* Active only when Input / Output Relay modules are installed in the proper slots

During normal operation mode, the LCD display is off. A short press on one of the two operator buttons automatically turns on the LCD display and switches to **Main Menu**.

If an error is active, it will appear as the first menu page in the menu structure. A short press on one of the two operator buttons switches from **ERROR** to **Main Menu** and vice versa.



- ERROR: error menu
- 2655: sum of the error codes
- Error Description: Sensor 1 Missing
- Error Description: Sensor 2 Missing
- ...

Paging through the Main Menu displays shows the calculator's most important data as shown below:

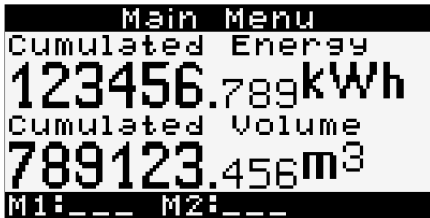

- 1x ▶
- Cumulated energy
- Cumulated volume

If the calculator is Heating only, then the Cumulated Energy and Cumulated Volume displays are dedicated to heating tariff. Tariff 1 is customizable.

If the calculator is Heating-Cooling, the Cumulated Energy display shows the heating energy, but the total volume will be shown: Heating and Cooling. Tariff 1 shows the cooling energy and cooling volume. Tariff 2 is customizable.

The Main Menu also shows the cumulated cooling energy and the cumulated cooling volume for combined heating/cooling meters.



**Dedicated to cooling mode energy**

- 1x ▶
- Cumulated energy tariff 1
- Cumulated volume tariff 1



**Active only in Heating/Cooling mode & Cooling mode**

- 1x ▶
- Cumulated energy tariff 2
- Cumulated volume tariff 2



- 1x ▶
- Cumulated Input value 1
- Cumulated Input value 2



**Active only when input module is in slot 1. This menu must be activated with Superprog Windows.**

- 1x ▶
- Cumulated Input value 3
- Cumulated Input value 4



```

Main Menu
Cumulated Value IN 5
000000000
Cumulated Value IN 6
000000000
M1:___ M2:___

```

Active only when input module is in slot 2.  
This menu must be activated with Superprog Windows.

- 1×▶
- Cumulated Input value 5
- Cumulated Input value 6

```

Main Menu
Temp. High/Low
20.0°C 20.0°C
Temp. Difference
0.00K
M1:___ M2:___

```

- 1×▶
- Temperature high
- Temperature low
- Temperature difference

```

Main Menu
Power
0.000kW
Flow
0.000m³/h
M1:___ M2:___

```

- 1×▶
- Thermal power
- Flow

```

Main Menu
Set day 1 date
1.1.2000
123456.789kWh
789123.456m³
M1:___ M2:___

```

- 1×▶
- Set day 1 date
- Energy cumulated to the specific date
- Total debit

```

Main Menu
Set day 2 date
1.1.2000
123456.789kWh
789123.456m³
M1:___ M2:___

```

- 1×▶
- Set day 2 date
- Energy cumulated to the specific date
- Total debit

- A long press on the right button does not have any function in **Main Menu** except for the last two screens where charts can be displayed.

## 6.7 Overview Menu

From any Menu, a two second press on the right button and the left button opens the Overview Menu and shows all available menus, as shown below.



- ◀: a short press moves the selection up
- ▶: a short press moves the selection down

- A two second press on the right button confirms the selection and opens the selected menu.

## 6.8 Metrological Setup

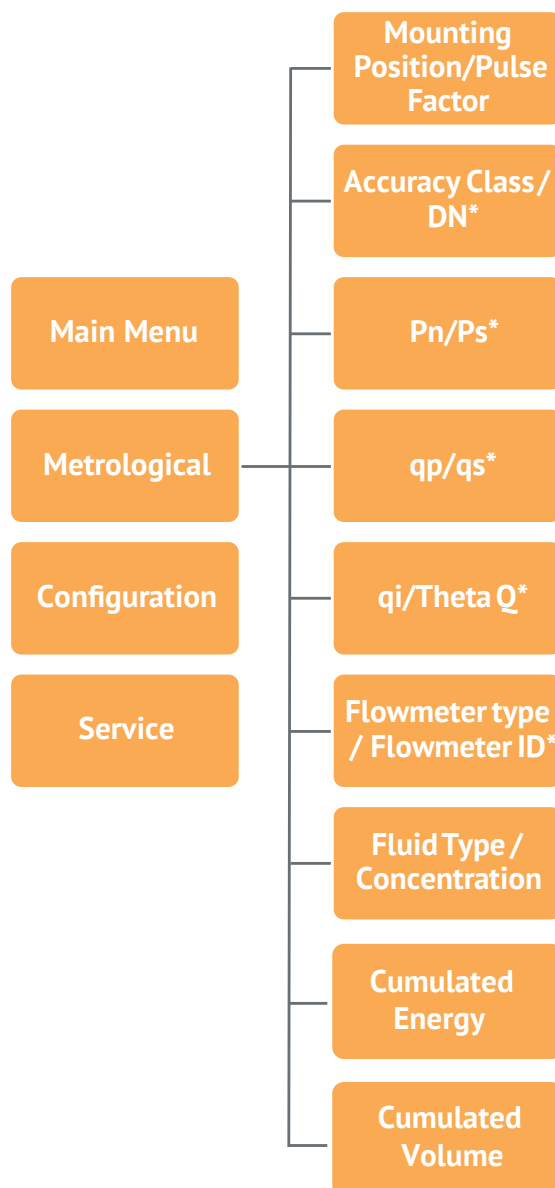

\* Active only for Supercal 5 S

The Metrological menu allows customers to set up and view **metrological** data, as shown below.



- 1x ▶
- Mounting position
- Electrical Pulse value



- Active only for Supercal 5 S
- 1x ▶
  - Accuracy class
  - DN: nominal diameter



- Active only for Supercal 5 S
- 1x ▶
  - PN: nominal pressure
  - PS: upper limit pressure



- Active only for Supercal 5 S
- 1x ▶
  - qp: permanent flow rate
  - qs: upper limit flow rate

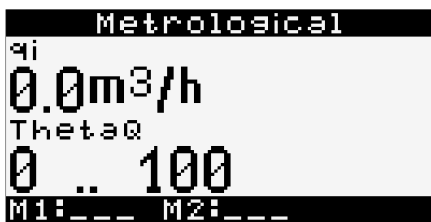

- Active only for Supercal 5 S
- 1x ▶
  - qi: lower limit flow rate
  - θq: temperature range



- Active only for Supercal 5 S
- 1x ▶
  - Flowmeter type
  - Flowmeter ID

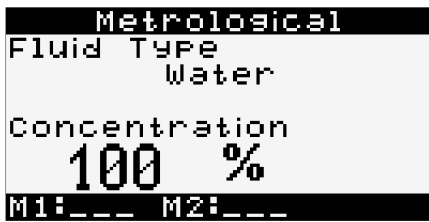

Active only for Supercal 5 S

- 1 × ▶
- Fluid type
- Concentration



- 1 × ▶
- Cumulated energy tariff 0 with five more significant digits



- 1 × ▶
- Cumulated volume tariff 0 with five more significant digits

- A long press on the right button has no function in **Metrological Setup**.
- A long press on the left button, selects the previous screen.
- A two second press on both buttons **simultaneously** selects the **Overview Menu**.

## 6.9 Stored Data

All the following data is stored in the internal memory of the Supercal 5 and it can be read from the Superprog Windows software:

- Totalizer values in a period of time
- Average values in a period of time
- Maximum values in a period of time
- Event log

## 6.10 Configuration

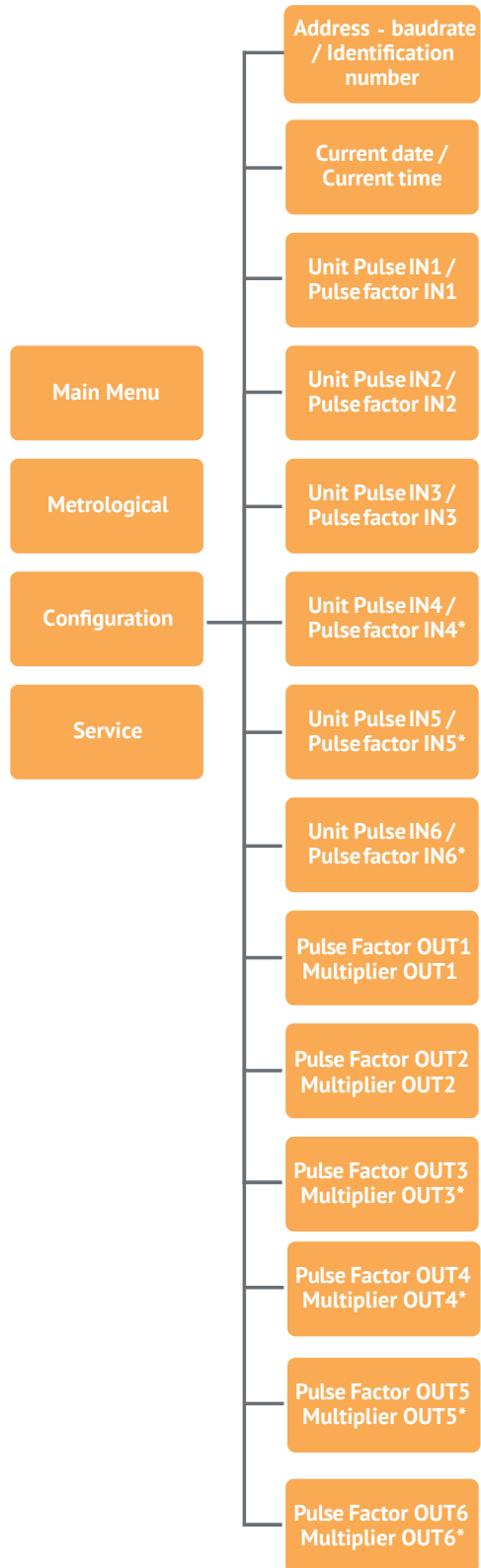

\* Active only when Input / Output Relay modules are installed in the proper slots

The Configuration menu allows customers to set and display the configured data, as shown below:



- Address
- Baud rate
- Identification number



- 1 × ▶
- Current date
- Current time

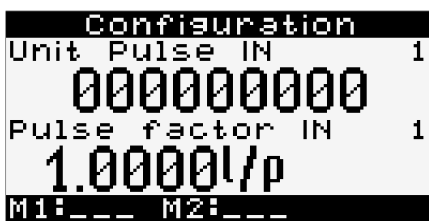

- 1 × ▶
- Electrical pulse Unit IN1
- Electrical pulse value IN1

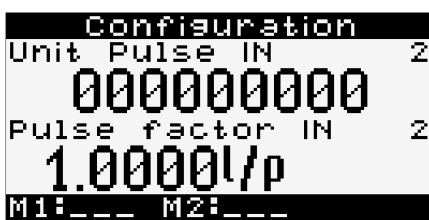

- 1 × ▶
- Electrical pulse Unit IN2
- Electrical pulse value IN2

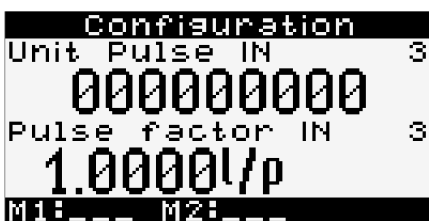

Active only when digital input module is in slot 1. This menu must be activated with Superprog Windows.

- 1 × ▶
- Electrical pulse Unit IN3
- Electrical pulse value IN3

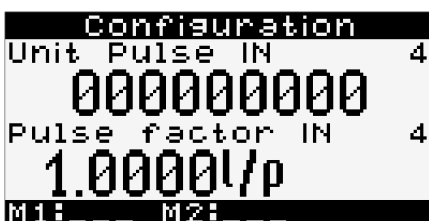

Active only when digital input module is in slot 1. This menu must be activated with Superprog Windows.

- 1 × ▶
- Electrical pulse Unit IN4
- Electrical pulse value IN4



Active only when input module is in slot 2. This menu must be activated with Superprog Windows.

- 1 × ▶
- Electrical pulse Unit IN5
- Electrical pulse value IN5

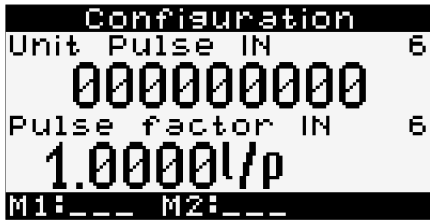

Active only when digital input module is in slot 2. This menu must be activated with Superprog Windows.

- 1 × ▶
- Electrical pulse Unit IN6
- Electrical pulse IN6

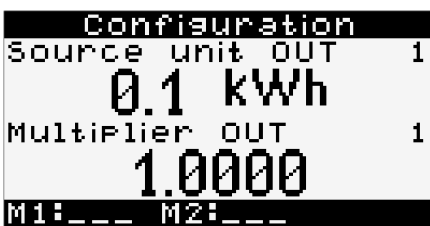

- 1 × ▶
- Pulse unit OUT1
- Multiplier OUT1 for number of pulses



- 1 × ▶
- Pulse unit OUT2
- Multiplier OUT2 for number of pulses

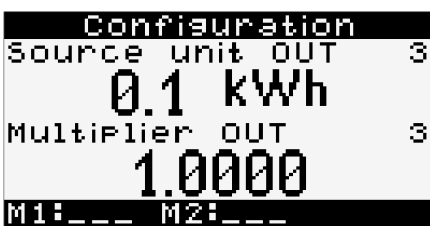

Active only when digital output module is in slot 1. This menu must be activated with Superprog Windows.

- 1 × ▶
- Pulse unit OUT3
- Multiplier OUT3 for number of pulses

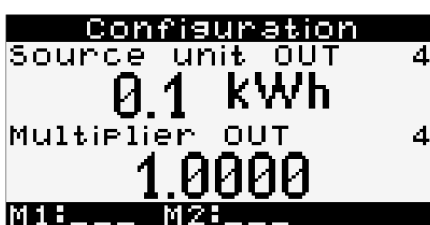

Active only when digital output module is in slot 1. This menu must be activated with Superprog Windows.

- 1 × ▶
- Pulse unit OUT4
- Multiplier OUT4 for number of pulses

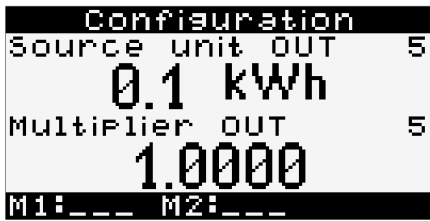

Active only when digital output module is in slot 2. This menu must be activated with Superprog Windows.

- 1 × ▶
- Pulse unit OUT5
- Multiplier OUT5 for number of pulses

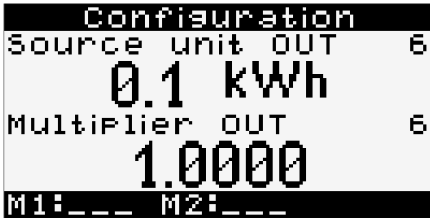

Active only when digital output module is in slot 2. This menu must be activated with Superprog Windows.

- 1 × ▶
- Pulse unit OUT6
- Multiplier OUT6 for number of pulses

- A long press on the right or left button does not have any function in the **Configuration**.
- A two second press on both buttons simultaneously opens the **Overview menu**.

## 6.11 Service

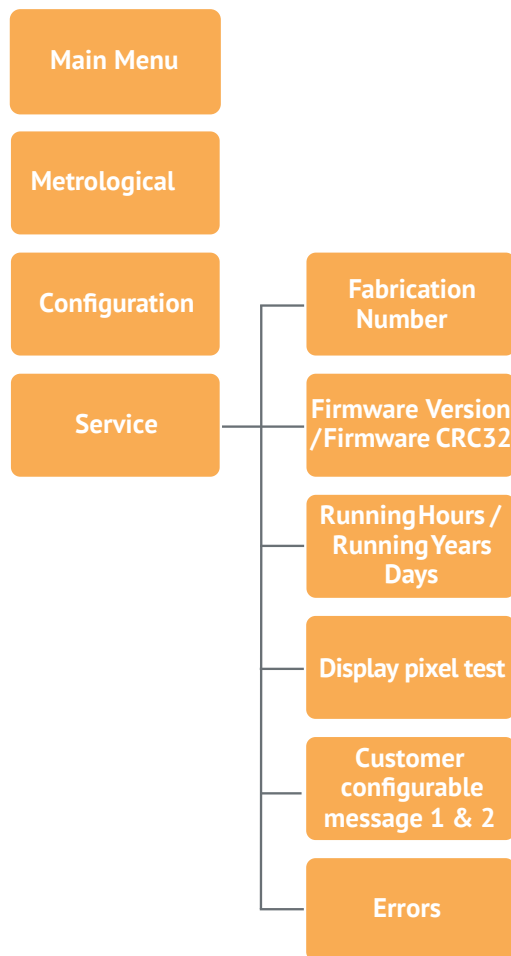



**Service** is customer's menu that contains informative data, as shown below.

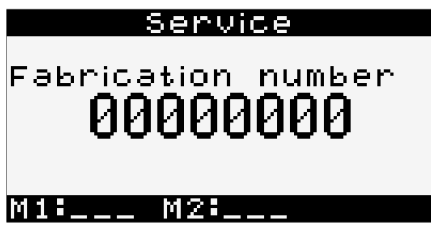

- 1 × ▶
- Serial number

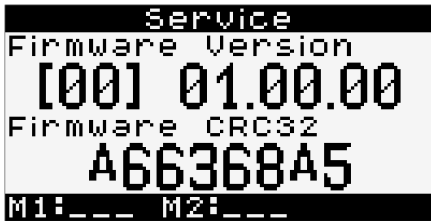

- 1 × ▶
  - Firmware version
  - Firmware CRC32
- \* Firmware version and CRC32 may be different for future firmware versions.



- 1 × ▶
- Running hours
- Running Years Days



- 1 × ▶
- Display pixel test: the screen must have every pixel on in this sub-menu.



- 1 × ▶
- Customer configurable message line 1
- Customer configurable message line 2

- A long press on the right button has no function in the **Service Menu**.
- A second long press on the left button opens the **Default Menu**.
- A simultaneous long press on both buttons selects the **Default Menu**.

## 6.12 Sealing

The sealing concept is subject to country-specific regulations. The sealing scheme shown here is built in to the Supercal 5 I.

Ex factory the Supercal 5 I is unsealed. The following installation steps must be carried out:

- Installing it to its final operating location
- Installing the two temperature sensors
- Installing the power supply if required
- Connecting the flowmeter to the Supercal 5 I

Then the Supercal 5 I must be sealed by using the menu on the display according to chapter 7.

The installer can modify any other metrological parameter with Superprog Android and Superprog Windows at any time.

Once the unit is sealed, in order to return to commissioning mode or to the *un-sealed* state, the seal must be broken as pictured below:

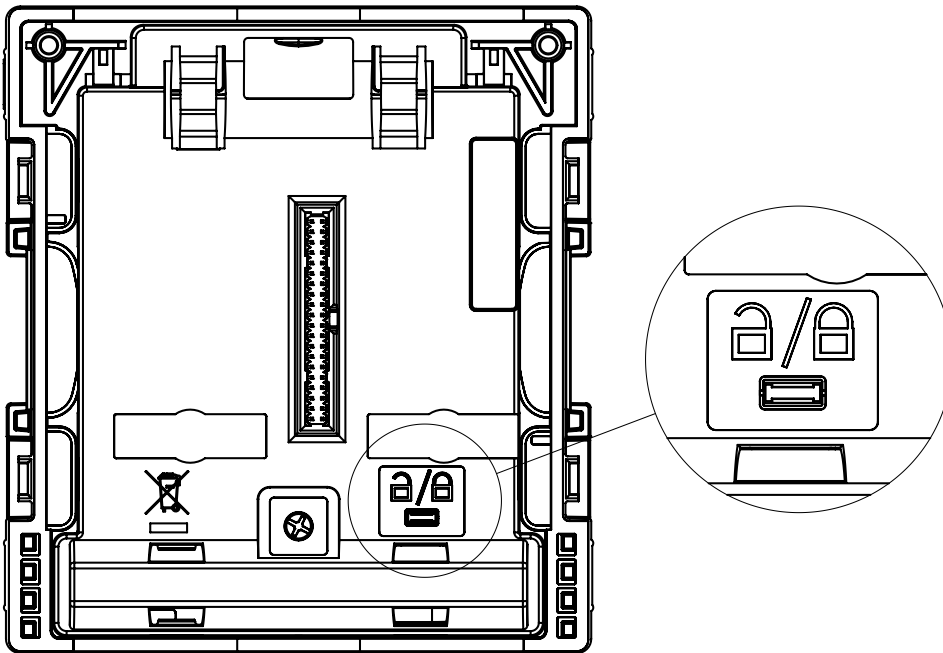

## 6.13 Nowa/Unicon

See chapter 11.11 Nowa/Unicon

## 6.14 Save Operating Data

### 6.14.1 Data Backup

The Supercal 5 has a non-volatile FRAM for data storage.

The data is thus retained even in the event of a power failure. All values are automatically updated and saved.

The historical data is organized in:

- Four totalizers
- One average value
- One maximum value
- One historical event

For each set of historical data, some customization is available:

- Maximum number of records
- Recording frequency

Historical events can be customized as follows:

- Maximum number of records
- Which event

The historical values can be downloaded from the Supercal 5 by M-Bus.

Totalizer history					Average value history	Peak value history	Event history
Period	Monthly	Biannually	Biannually	Biannually	Monthly	Monthly	
Register number	60	30	2	2	60	60	60
	Energy	Energy	Energy	Energy	Flow	Flow	Date
	Volume	Volume	Volume	Volume	Power	Power	Hour
	Energy 1	Energy 2	Energy 3	Energy 4	High Temperature	High Temperature	Event
	Volume 1	Volume 2	Volume 3	Volume 4	Low Temperature	Low Temperature	
	Energy 2	Energy 3	Energy 4	Energy 5	Delta Temperature	Delta Temperature	
	Volume 2	Volume 3	Volume 4	Volume 5			
	A1	A1	A1	A1			
	A2	A2	A2	A2			

The storage frequency can be set to:

- Hourly (hh:00)
- Daily (00:00)
- Monthly (on any day)
- Every six month (starting on the 1st of any month and ending on the 28th of any month)

Each of the three historical totalizers can store one of the following values:

- Energy
- Volume

Average values can be stored periodically every:

- Fifteen minutes (hh:00, hh:15, hh:30, hh:45)
- Thirty minutes (hh:00, hh:30)
- Hourly (hh:00)
- Daily (00:00)

The following average values are stored:

- Flow
- Thermal Power
- Hight temperature
- Low temperature
- Delta Temperature

Peak values can be stored periodically:

- Daily (00:00)
- Monthly (on any day)

The frequency for recording peak values must be a multiple of the average recording frequency.

The following average and peak values can be stored:

- Flow
- Thermal Power
- Hight temperature
- Low temperature
- Delta Temperature

The date and time is recorded with each stored value.

Superprog Windows or Superprog Android can be used to set which events can trigger the recording of the event together with the time, date, value and event number.

## 7. Commissioning

Make sure that all final checks have been performed before putting your device into operation.

### 7.1 Commissioning of the Supercal 5

The new Supercal 5 has a backup battery with 10 years life-time, and doesn't require any other type.

#### 7.1.1 Checking Date and Time

The date and time must be set correctly. This is essential for correct chronological display of Supercal 5 data.

The date and time can be set using the Android tool and Superprog software and the optical interface.

Time and date are normally already set.

#### 7.1.2 Flow Control

If the flow sensor's signal is received correctly, the current flow will be displayed immediately.

#### 7.1.3 Checking the Temperatures

If the temperature sensors in a heating system have been correctly installed and connected to the Supercal 5, the temperatures will be displayed as follows:

The "high temperature" must be greater than the "low temperature" and the temperature difference should be positive.

## 7.2 Uses

### 7.2.1 Flow Calculation

The parameters relevant to flow calculation (reading accuracy, minimum and maximum waiting time) are set in the factory. If necessary, authorized test centres can make changes using Superprog Android and Superprog Windows.

A flow calculation is based on three parameters:

- Maximum waiting time is:
  - 30 seconds for the 440 flowmeter
  - 120 seconds for any other flowmeter

Maximum waiting time can be customized by software.

- Minimum waiting time is:
  - 3 seconds if external power supply is being used.
  - 10 seconds if there is no external power supply.

Minimum waiting time cannot be customized.

About the flow calculation:

- A new flow calculation is started when the second pulse arrives in the period of time between the minimum and the maximum waiting time previously setup.
- The flowmeter can calculate a new value only if electrical pulses occur in this period of time. Otherwise the result is 0.

### 7.2.1.1 Reaction Time and Accuracy of the Flow Calculation

The time the Supercal 5 takes to perform a new flow calculation is called the reaction time.

The current flow rate appears simultaneously on the:

- LCD display
- M-Bus protocol (if available)
- Analog output (if available)

## 7.3 Software Superprog Windows and Superprog Android.

Superprog software allows you to read and modify all data in the Supercal 5. Superprog Windows for PCs communicates with the Supercal 5 using an optical connector or by M-Bus.

Superprog Android allows you to read and modify some data in the Supercal 5. Superprog Android can be installed on any Android phone. Communication between the Android phone and the Supercal 5 uses an NFC connector.



- Please Refer the SuperProg manual for further information concerning the use of the software.

### 7.3.1 Download the Superprog Windows and Superprog Android.

Both software can be downloaded from the Sontex Extranet at <https://extranet.sontex.ch/index/>

Only authorized users have access to the extranet.

Information and access rights to the Sontex Extranet can be obtained from your local Sontex representative.

#### 7.3.1.1 Solar and Refrigeration Systems

The Supercal 5, while initially calibrated for water, provides precise measurement even with glycol mixtures. Here, the medium to be measured, and its average mixing ratio is set according to the customer's requirements. If this is the case, the computer also processes and calculates negative temperatures.

The dust and splashproof housing with IP65 enclosure protection is suitable for refrigeration systems. The insulation regulations must generally be adhered to for refrigeration systems. Official calibration is not possible for glycol mixtures in solar and refrigeration systems.

#### 7.3.1.2 Tariff Functions and/or Status Message Signal

In addition to the cold/heat tariff, the Supercal 5 has a wide range of customer-specific tariffs. These can be defined using appropriate threshold values.

Various and complex conditions defining additional tariffs can be set up using Superprog Windows.

They can be programmed via the optical or M-Bus interface without breaking the calibration seal.

Examples of rate types:

- Tariffs based on current flow rate
- Tariffs based on current power
- Tariffs based on low temperature or high temperature
- Tariffs based on temperature difference
- Tariffs based on an internal tariff timer
- Cold/heat metering

### 7.3.1.3 Power Supply

Either batteries or power supply modules can be used. The type of power supply can be converted at any time. The Supercal 5 automatically detects the type of power supply installed.

### 7.3.1.4 Error Output

The error output can be used as an alarm contact to signal the freely selectable error states of the heat meter.

The error outputs are programmed using the Superprog Windows.

An error output becomes active if at least one of the selected error messages of the heat meter is present.

The event is stored with its time, date, value and event number.

## 8. Maintenance

No exceptional maintenance work is required for the electronic device.

### 8.1 Cleaning

The front of the housing can be cleaned with a dry, soft cloth

## 9. Troubleshooting



**For service requests, please have the serial number of the device and the error number ready!**

Please always state the error number and the Service menu's information (identification number corresponds to the serial number, etc.) for service requests.

The Service menu is used to analyze the device functions and offers comprehensive assistance in troubleshooting. To find the causes of the electronic device errors or alarm messages, proceed as described in chapter 9.1 General Troubleshooting Procedure.

### 9.1 General Troubleshooting Procedure

See Chapter 9.3.1.

If this doesn't lead to success, please contact your Sontex representative. The contact details can be found on the Internet at [www.sontex.ch/contact/](http://www.sontex.ch/contact/).

### 9.2 Fault Indication



All error messages are automatically cleared on the LCD display 60 seconds after troubleshooting.

The Supercal 5 displays the errors on the LCD with a description.

## 9.3 Error Messages



- If several errors are present at the same time, the individual error messages are added together and displayed.
- If an error occurs for more than one hour, it is stored in the error memory with date and time (start of error) and duration (in minutes). If an error is present for less than 60 minutes, it is deleted automatically without being saved.

### 9.3.1 Overview of Error Messages

Code Error	LCD Reference	Description	Procedure Troubleshooting
1	A/D reference 1	Temperature reference 1 A/D: A temperature sensor cable is interrupted or not connected.	Check if the sensor probe is connected. If yes, the sensor probe is defective.
2	A/D reference 2	Temperature reference 2 A/D: A cable of the temperature sensor is interrupted or not connected.	Check if the sensor probe is connected. If yes, the sensor probe is defective.
4	Temperature sensor 1 A/D error	Temperature reference 1 A/D: A cable of the temperature sensor is connected but its value can not be read out.	Swap the probes. If Err2 appears afterwards, probe 1 is defective or the wrong type.
8	Temperature sensor 2 A/D error	Temperature reference 2 A/D: A cable of the temperature sensor is connected but its value can not be read out.	Swap the probes. If Err1 appears afterwards, probe 2 is defective or the wrong type.
16	Range Sensor 1	Temperature sensor 1 <= min. Range error	Check the actual temperature being measured and the physical installation of the sensor.
32	Range Sensor 1	Temperature sensor 1 >= max. Range error	Check the actual temperature being measured and the physical installation of the sensor.
64	Range Sensor 2	Temperature sensor 2 <= min. Range error	Check the actual temperature being measured and the physical installation of the sensor.
128	Range Sensor 2	Temperature sensor 2 >= max. Range error	Check the actual temperature being measured and the physical installation of the sensor.
512	Flow Saturation	The flow rate is higher than 1,5 qp	Reduce the flow rate.
1024	OPEN CASE	The SC5 is open	Close the case
2048	Main power cut	Power outage	Check the main power supply connection.
4096	M1 Power Supply	Error in module 1: Details must be found into specific module error	
	M1 Unsupported		
	Slot left error		
8192	M2 Power Supply	Error in module 2: Details must be found into specific module error	
	M2 Unsupported		
	Slot right error		

Note: Any combination of errors corresponds to the arithmetic sum of each code. The error code is displayed on the electronic device's display.

## 9.4 Troubleshooting M-Bus

If there is no communication via the M-Bus with the Supercal 5, please check:

- Does the device address in the device match the master?
- Do device and master have the same baud rate?
- Are there other devices with the same device address on the M-Bus?
- Is the M-Bus correctly connected to the device?

## 9.5 Troubleshooting MODBUS

- Do device and master have the same baud rate and parity?
- Is the wiring of the interface OK?
- Do all slaves on the MODBUS have different device addresses?

# 10. Decommissioning

## 10.1 Exchange and Return

In the event of repair, factory calibration, incorrect delivery or order, the calculator must be returned. As an ISO-certified company, Sontex is required by law to handle all returned products in a specific manner.

To ensure a safe, professional and fast return of your device, please refer to the Sontex website for procedures and conditions and use our Return of Goods Form as described in Chapter 14. Return of goods form see also [www.sontex.ch/downloads](http://www.sontex.ch/downloads).

## 10.2 Disposal



To preserve and protect the environment and reduce waste of natural resources and pollution, the European Commission has adopted a directive whereby electrical and electronic equipment is taken back by the manufacturer for proper disposal or recycling

If you carry out the disposal, the Supercal 5 must be disposed of under the applicable local environmental regulations. Find out about recycling opportunities in your region

### 10.2.1 Disposal



This symbol indicates that electrical and electronic equipment must be disposed of separately.

The following applies to consumers in European countries:

- This product must be disposed of separately at a suitable collection point. Do not dispose of it with your household waste!
- Through separate disposal and recycling, natural raw materials can be preserved and the harmful consequences for human health and the environment caused by incorrect disposal can be prevented.
- Further information can be obtained from your specialist dealer or from the authorities or companies responsible for waste disposal.



# 11. Technical Information

## 11.1 Calculator Supercal 5

### Technical Data

<b>Temperature Measurement</b>	<ul style="list-style-type: none"> <li>■ Pt500 according to EN 60751</li> <li>■ 2- or 4-wire</li> <li>■ Absolute temperature range</li> <li>■ Approved range</li> <li>■ Homologation range</li> <li>■ Response limit</li> <li>■ Temperature resolution t</li> <li>■ Temperature resolution <math>\Delta t</math></li> <li>■ Environment class A</li> </ul>	<p>-20 °C to 200 °C  1 °C to 200 °C  3 K to 150 K  0,2 K  0,1 K  0.01 K  E1/M1</p>
<b>Temperature Measuring Cycle</b>	<ul style="list-style-type: none"> <li>■ Battery operated</li> <li>■ Mains operated</li> </ul>	<p>10 s  3 s</p>
<b>Medium Temperature</b>	<ul style="list-style-type: none"> <li>■ Operation</li> <li>■ Storage and transport</li> </ul>	<p>5 °C to 55 °C  -20 °C to 70 °C (dry environment)</p>
<b>Display</b>	<ul style="list-style-type: none"> <li>■ Illuminated dot-matrix</li> </ul>	<p>128 × 64 pixels</p>
<b>Display Units</b>	<ul style="list-style-type: none"> <li>■ Energy</li> <li>■ Volume</li> <li>■ Additional pulse inputs</li> <li>■ Temperature</li> </ul>	<p>kWh, MWh, MJ, GJ, kBtu, MBtu, Mcal, Gcal  L, m<sup>3</sup>, gal (US), kgal (US), ft<sup>3</sup> (US)  Energy or volume  °C, °F</p>
<b>Lifespan Supply Modules</b>	<ul style="list-style-type: none"> <li>■ w/o supply</li> <li>■ D battery</li> </ul>	<p>6 + 1 years (backup for metrological part)  12 + 1 years</p>
<b>Degree of Protection</b>	<ul style="list-style-type: none"> <li>■ IP Code</li> </ul>	<p>IP 65 in accordance to IEC 60529</p>
<b>Pulse Inputs</b>	<p><b>Frequencies</b></p> <ul style="list-style-type: none"> <li>■ Without supply</li> <li>■ D battery</li> <li>■ External Mains</li> </ul> <p><b>Input voltage</b></p>	<p>maximum 5 Hz  maximum 200 Hz  maximum 200 Hz  0 to 30 V</p>
<b>Pulse Outputs</b>	<p><b>Frequencies</b></p> <ul style="list-style-type: none"> <li>■ Without supply</li> <li>■ D battery</li> <li>■ External Mains</li> </ul> <p><b>Output voltage</b></p>	<p>maximum 5 Hz  maximum 200 Hz  maximum 200 Hz  0 to 60 V</p>
<b>Optical interface</b>	<ul style="list-style-type: none"> <li>■ Interface</li> </ul>	<p>according to IEC 62056-21:2002</p>
<b>NFC Interface</b>	<ul style="list-style-type: none"> <li>■ Interface</li> </ul>	<p>according to ISO/IEC 14443 Type A</p>
<b>M-Bus interface</b>	<ul style="list-style-type: none"> <li>■ Interface</li> <li>■ Baud rate</li> <li>■ Galvanic isolation</li> </ul>	<p>according to EN 13757-2/3  300 to 9600 baud  3.75 kV</p>

## 11.2 Power Supplies

The Supercal 5 is always supplied with a battery and can also be supplied with mains power supply module. These can be modified and retrofitted at any time.

### 11.2.1 Mains Modules

#### 12- 24 VDC or 12- 36 VAC Article number: SC5X00011

Type	safety extra-low voltage
Voltage tolerance	+10/-15 %
Relative Humidity	93 %
Galvanic isolation	Yes

#### 110- 230 VAC – 50/60 Hz. Article number SC5X00012

Type	Protection class II
Frequency	50/60Hz
Input voltage range	90–260V
Relative Humidity	93 %
Protection	6A

### 11.2.2 Battery Modules

#### Lithium D – Cell Article Number SC5X00010

Nominal voltage	3,6V
Life	up to 12 +1 year (in combination with self-sufficient flow sensors)
Maximum ambient temperature	55 °C

#### Backup battery

type	A (standard ANSI) with connector
Nominal voltage	3,6VDC
Nominal capacity	min. 4,1 Ah
Maximum ambient temperature	55 °C

### 11.2.3 Estimating the Battery Life of an M-Bus Application

The battery life of Supercal 5 **doesn't** depend on any of these parameters:

- Number of M-Bus devices attached to the M-Bus network
- Network specifications, communication speed
- Ambient temperature (5 °C–55 °C)

## 11.3 Measurement concept

- The Supercal 5 measurement calculation is based on volume calculation. The number of electrical pulses determines the volume directly.
- Once the volume is determined, the flow rate is calculated according to this volume, and the time taken for the pulses to occur.
- The heat transfer is calculated from flow rate and the difference between “high temperature” and “low temperature”.
- The heat capacity and density of the heat transfer medium are included in the calculation.

- Its flow rate is determined with a suitable flow sensor.
- A pair of temperature sensors determine the “warm pipe temperature” and the “cold pipe temperature” of the heat transfer medium. When  $\Delta T > 0,2 \text{ K}$ , the energy consumed is calculated.
- The cooling energy is calculated when  $\Delta T < 0,2 \text{ K}$  and the “cold pipe temperature”  $< 18 \text{ }^\circ\text{C}$ . This threshold value can be set on demand.

## 11.4 Arithmetic Logic Unit

Modern calculators should be able to meet a large number of user related and technical requirements, such as:

- Good readability of the arithmetic unit displays
- Logical and clear menu structure
- Servicability
- Low costs when changing meters
- Flexibility with regard to use of different flow and temperature sensors
- Modularity over equipment with device options such as data inputs and outputs, etc.
- Highest measurement accuracy and data security
- In general, each calculator should be clearly assigned to a heat measuring point and easily accessible/readable.

Electromagnetic interference and overheating at the installation site must be avoided at all costs. All cables must be laid at a minimum distance of 300 mm from power and high-frequency cables.

## 11.5 Flow Sensors

The following common types of flow sensor can be used:

- Vibrating jet flow sensors
- Wing and turbine wheel meters
- Magnetic-inductive flow sensors
- Ultrasonic flow sensors

The following criteria can influence the selection of the flow sensor:

- Type of measurement (heat/cold measuring point, viscosity of the medium, etc.)
- Installation requirements
- Accuracy requirements for the flow sensor
- Available inlet/outlet distances (measuring accuracy)
- Price/performance

In order to achieve the highest possible resolution, the pulse factor (pulses per unit volume) should always be high.

The installation location of the flow sensor (“cold side” or “warm side”) is just as important, because the conversion from the volume passing through to the mass passing through takes place at the temperature assigned to the installation location.

As a rule, the flow sensor is installed where the ambient temperature is closest to room temperature.

This results in a higher measurement accuracy and a longer service life of the flow sensor.

## 11.6 Flow Measurement

Type-approved flow sensors with a pulse or frequency output can be connected to the Supercal 5 .

The calculator has the following input pulse values:

- Up to 999,999 pulses/litre
- Up to 999,999 litres/pulse

## 11.7 Flow Calculation

Flow calculation is based on the time elapsed between impulses from the flow sensor.

For the first flow calculation, the calculator requires two volume pulses for the calculation of the effective flow. Depending on the configuration, the internal flow rate calculation and the immediate display of the current flow rate on the LCD display take place.

### Configuration

The frequency of flow calculation depends on:

- The number of volume pulses arriving in a predetermined time interval (minimum/maximum waiting time).
- The desired accuracy of the flow calculation.
- The flow calculation parameters are set at the factory and can only be changed by authorised test centres.

### 11.7.1 Calculation of the Flow Rate with Conventional Flow Sensors

With conventional flow sensors, such as mechanical flow sensors, the pulse value is given in **litres/pulse** or the time for a measuring period in seconds.

The formula for the current flow rate in liters per hour is then:

Flow rate (L/h)	$kw \times 3,600 \times \text{imp}/\text{time}$
kw (litre/pulse)	pulse valence
Imp	number of pulses per measuring period
Time	duration of the measuring period [s].

### 11.7.2 Calculation of the Flow Rate with Fast Flow Sensors

For fast flow sensors, the pulse valency is specified in **pulse/litre**.

The formula applies accordingly:

Flow rate (L/h)	$3,600/\text{time} \times \text{Pulse}/\text{pf}$
pf (pulse/litre)	pulse factor
Pulse	number of pulses per measuring period
Time	duration of the measuring period [s].

## 11.8 Temperature Measurement

### 11.8.1 General Information

The basic measuring range of the calculator is  $-20\text{ }^{\circ}\text{C}$  to  $+200\text{ }^{\circ}\text{C}$ .

Approved according to MID, the measuring range is  $2\text{ }^{\circ}\text{C}$  to  $200\text{ }^{\circ}\text{C}$ . There is no approval below  $2\text{ }^{\circ}\text{C}$  according to today's valid approval regulations.

As standard, the Supercal 5 is designed for Pt500 temperature sensors. The temperature sensors can be connected using two-wire or four-wire technology. The temperature measurement itself is carried out according to the "dual slope method". An integrated calibration system ensures high measurement resolution and measurement stability.

If the equipment is connected to a 440, the measurement timing is:

- Between 3 seconds and 30 seconds if the calculator has an external power supply.
- Between 10 seconds and 30 seconds if the calculator has no external power supply.

If a different flow sensor is used:

- Between 3 seconds and 120 seconds if the calculator has an external power supply.
- Between 10 seconds and 120 seconds if the calculator has no external power supply.

## 11.8.2 Permissible Errors and Limit Values

With permanently connected temperature sensors, the maximum permissible error (in %) is calculated according to the equation:

$$E_t = \pm (0,5 + 3 \Delta\theta_{\min} / \Delta\theta)$$

$\Delta\theta_{\min}$  = permissible minimum temperature difference = 3 K  
(according to MID EC type-examination certificate)

With permanently connected temperature sensors, the screws of the connection terminals are secured with an adhesive seal. A subsequent exchange of the temperature sensors is therefore not possible without damaging the seal.

The software of the calculator checks whether the measured temperatures are within the permissible measuring range.

If this measuring range is exceeded, the calculator indicates a measuring error.

## 11.9 Energy Measurement

### 11.9.1 Error limits

Heat flow can be determined from the knowledge of the mass, its specific heat capacity and the temperature difference.

Here the difference of the enthalpy between the "temperature high" and the "temperature low" during a given time  $t$  is integrated. The equation for calculation of thermal energy according to EN 1434-1, point 8, is used here.

The permissible error is calculated retrospectively:

$$E_c = \pm (0,5 + \Delta\theta_{\min} / \Delta\theta)$$

The minimum temperature difference  $\Delta\theta_{\min}$  depends on the assembly of the subassemblies. If the calculator and temperature sensor are tested as a unit, it is 2 K according to PTB approval and 3 K according to MID approval.

No approvals below 3 K are provided for the EC type-examination certificate.

### 11.9.2 Cooling Energy

If a heat meter is used to measure the cooling energy in the return flow, the "temperature sensor low" is installed in the flow and the "temperature sensor high" in the return flow.

The Supercal 5 I are generally tested ex works in accordance with the metrological measuring points of EN1434 (2006) for refrigeration and heat energy.

### 11.9.3 Refrigeration Energy – Combined Cold/Heat Meter

A calculation of the cooling energy for the combined cold/heat meter (tariff function cold/heat tariff) takes place if the following two conditions are fulfilled simultaneously:

- Temperature difference ( $\Delta t$ ) < -0,2 K
- "Cold pipe Temperature" < 18 °C

The threshold value of 18 °C for switching over the combined cold/heat meter is set at the factory. It can be changed using the Superprog software via the optical interface.

If the calculator is used for combined heat and cooling measurement, cooling capacity and temperature difference are displayed with a minus (-) and the corresponding values are assigned to tariff 1.

For the measurement of cold energy, an officially certified calibration can only take place if the cold energy is determined within the permitted temperature range with the medium water (without glycol).

### 11.9.4 Insulation Regulations for Refrigeration Systems

In refrigeration systems, the mechanical flow sensors and the temperature sensors may only be insulated up to the screw connection.

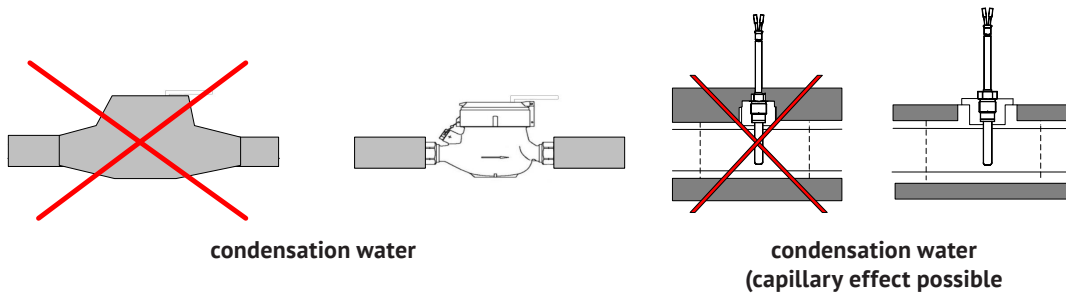

### 11.10 Calibration and Measurement Data

If calculators are used for the direct billing of energy between energy supplier and consumer (public payment transactions), they are subject to calibration in most EU countries.

The purpose of the calibration obligation is to protect both the consumer of energy and the supplier from deliberate fraud and harmful manipulation.

Only type-approved measuring instruments can be calibrated. This prevents unsuitable systems from being used.

They are determined in the factory or by an authorized authority. They are consequently protected against unauthorized intervention by calibration seals.

In particular, the following parameters of a calculator are subject to calibration:

- Pulse valence/factor and installation location of the flow sensor
- Cumulated energy and volume with associated units
- Display ranges and units of power, flow and temperature

They are determined in the factory or by an authorized authority. They are consequently protected against unauthorized intervention by calibration seals.

If these calibration-relevant safety symbols are damaged or removed, all warranty/service warranties and the calibration of the calculator expire.

### 11.11 Nowa

“NOWA” means “**N**ormalized heat meter adapter”.

The NOWA interface is a standardized interface that establishes the connection to the control of the custody transfer test bench via a modern calculator interface.

The relevant data of the calculators are recorded employing test benches operated by the custody transfer office and the necessary adjustment, calibration, and parameterization are carried out in the course of the custody transfer test.

All modern calculators have so-called standardized interfaces. However, these are designed for the standardized readout of the calculators, but not for their adjustment, calibration and parameterization via a custody transfer test bench.

Besides, the manufacturers of modern calculators have not yet implemented a uniformly defined telegram structure for the calculator interfaces. The development of the NOWA adapter has become necessary.

Schematic representation of a custody transfer test bench.

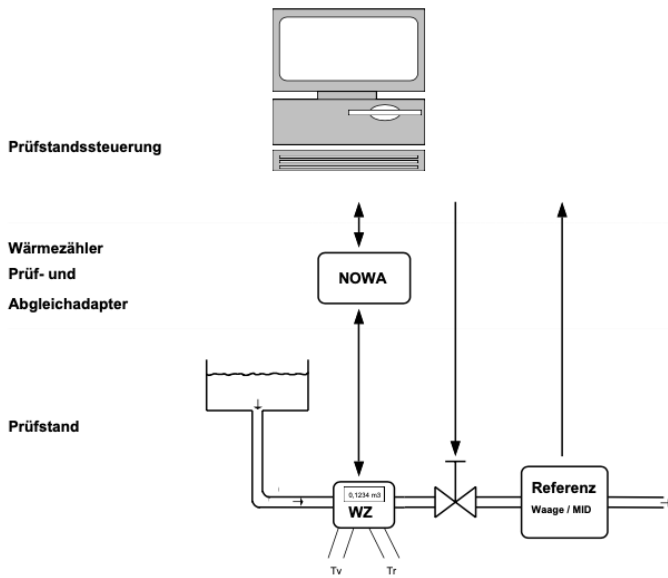

The interfaces of the NOWA adapter

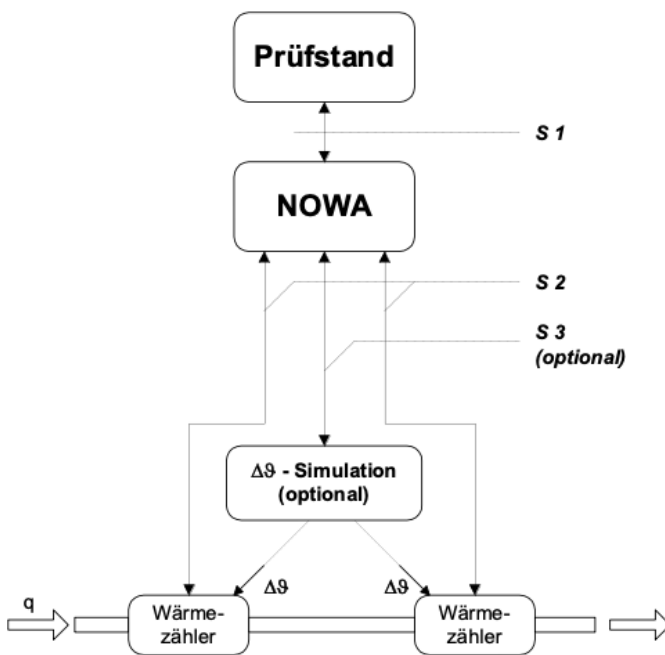

The test bench communicates the NOWA function via the S1 interface based on defined specifications.

Via the interface(s) S2, NOWA controls the calculators according to the function specified by S1. NOWA controls an optional electronic device for the simulation of temperature sensors via the S3 interface.

The NOWA system can be used with manual or semi-automatic test benches and automatic versions.

Due to its flexible design of the S2 interface, up to 15 arithmetic units can be subjected to custody transfer testing at the same time. Multiplexing makes it possible to integrate more than 15 DUTs and to guarantee additional functional extensions (e.g. higher data transfer rates, parallel transmission, etc.).

Further advantages of the NOWA concept:

- High security against errors in the handling of test sequences
- Cost reduction regarding production and quality assurance for the manufacturers of calculators.
- Improving consumer protection.

## 12. Notes on Project Planning

### 12.1 Safety and Security

The Supercal 5 calculator is produced in accordance with the state of the art and complies with EN1434 and is reliable in operation. If the calculator is operated outside the specifications defined here or is not handled in accordance with the regulations, all Sontex service and warranty services will be void.

### 12.2 Local Regulations

The following regulations must be observed:

- Local regulations for electrical installations
- Local regulations for the use of heat meters

### 12.3 Power Supply

- In the case of mains-operated calculators, an uninterruptible power supply must be guaranteed.
- Local regulations for electrical installations should be ensured.
- Over-, under- and surge voltages are not permitted.
- Installation information for the installation of heat meters and temperature sensors according to EN1434-2 and EN1434-6

### 12.4 Lightning protection

Protective measures against lightning protection must be taken within the power supply networks or bus systems.

### 12.5 Bus Facilities

#### **NOTICE**

##### **Destruction of arithmetic unit!**

In all bus systems, galvanic isolation from the flow sensors must be ensured. Otherwise the calculator may be destroyed!



## 12.6 Refrigeration Plants

- The insulation regulations must be observed.
- The calculator must generally be mounted separately from the cooling pipe.

## 12.7 Assembly

- The assembly instructions are supplied as standard. Your specifications must be observed during installation and commissioning.
- For temperature sensors with a cable length of more than 3 m, shielded temperature sensor cables must generally be used. The shielding must be properly connected to the ground using the supplied mounting clamps.
- It must be ensured that all earthing connection points of the overall installation (mains, external supply, chassis of the flow sensor and calculator) are potential equal.
- Ensure correct grounding.

## 12.8 Lead Sealing

- Each calculator must be provided with the necessary seals to protect it against unauthorised access.
- Safety symbols relevant to calibration must not be damaged or removed! Otherwise the calibration of the calculator as well as all warranty and service guarantees will expire.
- User seals may only be removed by authorized persons in the course of services. They must be renewed after the service has been completed.

## 12.9 Service and Repairs

Service and repair work may only be carried out by qualified personnel who have been expressly authorized by Sontex.

## 12.10 Installation Information



- The calculator must generally be mounted separately from the heat or cold pipe.
- Ensure that no condensation water can run into the calculator along the connected lines.
- If there is a risk of vibrations in the piping system, the calculator should be mounted separately on the wall.
- For medium temperatures above 90 °C, the calculator should be mounted remotely.
- The flow sensor should be mounted between two shut-off valves.
- For the flow sensor, the direction of flow must be observed (arrow on the flow sensor).
- The pipeline must be flushed before mounting the flow sensor to ensure that there are no foreign bodies in the pipeline.
- The lines must be vented during commissioning. Air in system or flow sensor may affect measurement result
- Only use suitable, new sealing material.
- The tightness of the various connections must be checked.
- Lightning protection cannot be guaranteed; this must be ensured via the house installation.

## 12.11 Minimum Distances



- All cables must be laid at a **minimum distance of 300 mm** from power and high-frequency cables.
- Radiant heat and electrical interference fields in the vicinity of the calculator must be avoided.

# 13. Appendix

## 13.1 Extra Information for Supercal 5 S

### 13.1.1 The “Cut Off” Function of the Superstatic 440

The combination of the Supercal 5 I with the Superstatic 440 static flow sensor defines and limits the possible flow measuring range ex works with a lower and an upper threshold value (“cut off” and “flow saturation”).

**The “cut off” function can only be stored in the calibration and measurement relevant part of the Supercal 731 by violating the calibration seal.**

As soon as the flow rate drops below the programmed “cut off”, no flow measurement takes place. Therefore, no volume is cumulated.

If the flow rises above the flow saturation, the flow measurement stagnates at  $2,4 \times$  nominal flow, but the volume is still cumulated. In this case the red led will light on and an error message event will be recorded.

The “cut off” function for the 440 flowmeter can also be used for hydraulic effects within the heating system, e.g. system vibrations. This makes the measurement less sensitive, which makes it easier to isolate a possible erroneous measurement.

In case of Supercal 5 S, the threshold values “cut off” and “flow saturation” are able to be customized by Software in Supercal 5 Calculator with *verifier* level user.

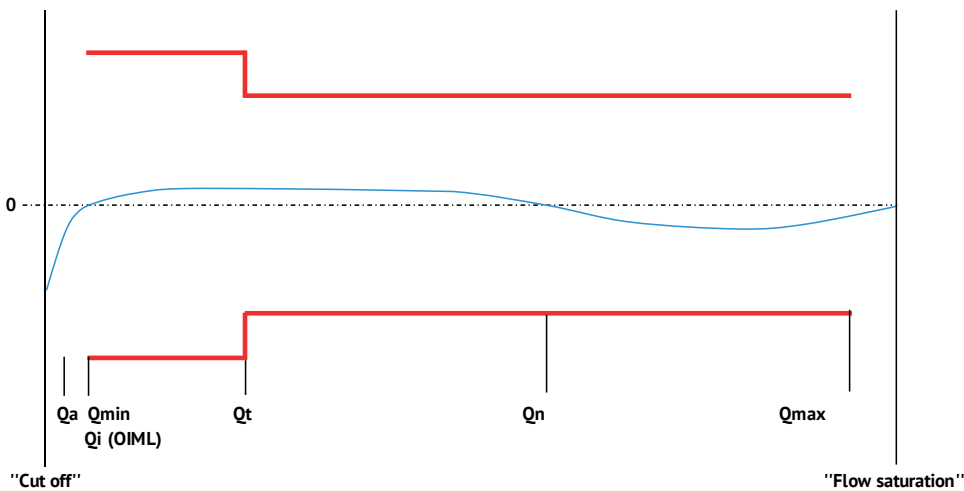

#### Note

- The threshold values of the “cut off” function are to be regarded as autonomous from the two additional threshold values specified in the standard ( $Q_a$  and  $Q_{min}$ ). However, the “cut off” value must not exceed  $Q_{min}$ .

**Table of factory-set threshold values according to PTB Metrological Class C.**

"Length (mm)"	Connection	"Qn (m <sup>3</sup> /h)"	"Qt (m <sup>3</sup> /h)"	"Qmin (m <sup>3</sup> /h)"	"Qa (50 °C) (m <sup>3</sup> /h)"	"Cut off (m <sup>3</sup> /h)"	"Flow saturation (m <sup>3</sup> /h)"
110	G 3/4"	1,0	0,060	0,010	0,004	0,003	2,400
110	G 3/4"	1,5	0,090	0,015	0,010	0,005	3,600
190	G 1"	1,0	0,060	0,010	0,004	0,003	2,400
190	G 1"	1,5	0,090	0,015	0,010	0,005	3,600
190	G 1"	2,5	0,150	0,025	0,010	0,008	6,000
260	G 1 1/4"	3,5	0,210	0,035	0,015	0,011	8,400
260	DN25	3,5	0,210	0,035	0,015	0,011	8,400
260	G 1 1/4"	6,0	0,360	0,060	0,030	0,018	14,400
260	DN25	6,0	0,360	0,060	0,030	0,018	14,400
300	G 2"	10	0,600	0,100	0,050	0,030	24,000
300	DN40	10	0,600	0,100	0,050	0,030	24,000
270	DN50	15	0,900	0,300	0,075	0,090	36,000
300	DN65	25	1,500	0,500	0,125	0,150	60,000
300	DN80	40	4,000	0,800	0,400	0,240	96,000
300	DN100	60	6,000	1,200	0,600	0,360	144,000
250	DN125	100	10,000	2,000	1,000	0,600	240,000
300	DN150	150	15,000	3,000	1,500	0,900	360,000
350	DN200	250	25,000	5,000	2,500	1,500	600,000
450	DN250	400	40,000	8,000	4,000	2,400	960,000

**Table of factory-set threshold values according to OIML R75 1988**

"Length (mm)"	Connection	"Qn (m <sup>3</sup> /h)"	"Qt (m <sup>3</sup> /h)"	"Qmin (m <sup>3</sup> /h)"	"Qa (50 °C) (m <sup>3</sup> /h)"	"Cut off (m <sup>3</sup> /h)"	"Flow saturation (m <sup>3</sup> /h)"
110	G 3/4"	1,0	0,200	0,010	0,004	0,003	2,400
110	G 3/4"	1,5	0,300	0,015	0,010	0,005	3,600
190	G 1"	1,0	0,200	0,010	0,004	0,003	2,400
190	G 1"	1,5	0,300	0,015	0,010	0,005	3,600
190	G 1"	2,5	0,500	0,025	0,010	0,008	6,000
260	G 1 1/4"	3,5	0,700	0,035	0,015	0,011	8,400
260	DN25	3,5	0,700	0,035	0,015	0,011	8,400
260	G 1 1/4"	6,0	1,200	0,060	0,030	0,018	14,400
260	DN25	6,0	1,200	0,060	0,030	0,018	14,400
300	G 2"	10	2,000	0,100	0,050	0,030	24,000
300	DN40	10	2,000	0,100	0,050	0,030	24,000
270	DN50	15	3,000	0,300	0,075	0,090	36,000
300	DN65	25	5,000	0,500	0,125	0,150	60,000
300	DN80	40	8,000	0,800	0,400	0,240	96,000
300	DN100	60	12,000	1,200	0,600	0,360	144,000
250	DN125	100	20,000	2,000	1,000	0,600	240,000
300	DN150	150	30,000	3,000	1,500	0,900	360,000
350	DN200	250	50,000	5,000	2,500	1,500	600,000
450	DN250	400	80,000	8,000	4,000	2,400	960,000

### 13.2 Pressure Loss Curve

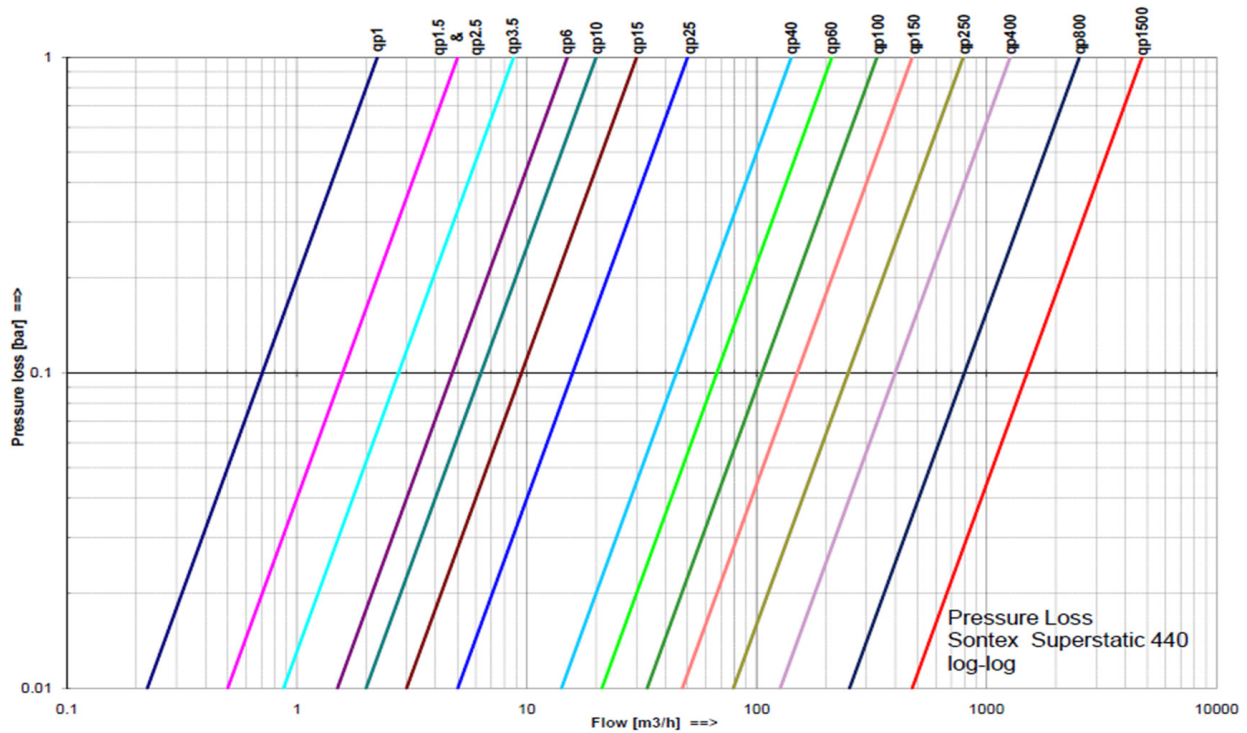

### 13.3 Dimension fluidic oscillator flow sensor Superstatic 440

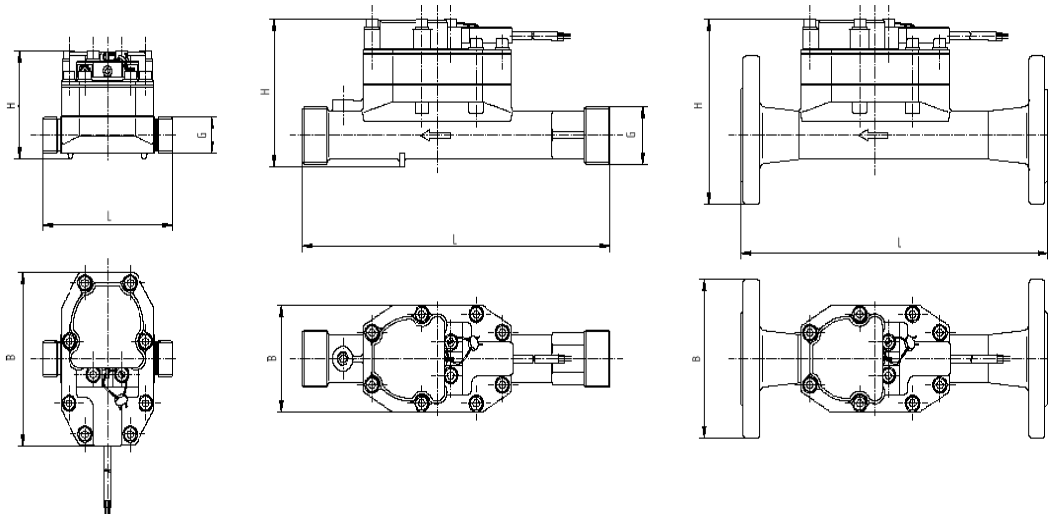

qp	DN	G	PN	Fig.No	B (mm)	H (mm)	L(mm)	h (Ø mm)	# bolts (M)
1 m³/h	-	¾"	16/25	1	125	79	110		
1 m³/h	-	1"	16/25		125	79	190		
1,5 m³/h	-	¾"	16/25		125	79	110		
1,5 m³/h	-	1"	16/25		125	79	190		
2,5 m³/h	-	1"	16/25		125	79	190		
3,5 m³/h	-	1 ¼"	16/25	2	78	105	260		
3,5 m³/h	25	-	16/25	3	115	134	260	Ø 85	4 (M 12)
6 m³/h	-	1 ¼"	16/25	2	78	105	260		
6 m³/h	25	-	16/25	3	115	134	260	Ø 85	4 (M 12)
10 m³/h	-	2"	16/25	2	78	122	300		
10 m³/h	40	-	16/25	3	150	157	300	Ø 110	4 (M 16)

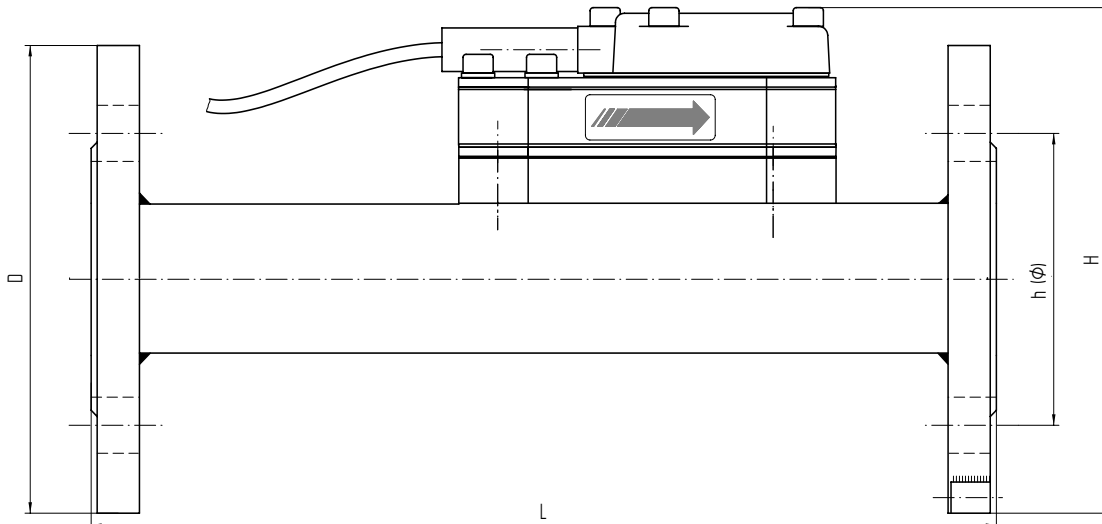

qp	DN	PN	L (mm)	D (mm)	H (mm)	h (Ø mm)	# bolts (M)
15 m <sup>3</sup> /h	50	16, 25	270	165	171	Ø125	4 (M 16)
25 m <sup>3</sup> /h	65	16, 25	300	185	189	Ø145	8 (M 16)
40 m <sup>3</sup> /h	80	16, 25	225	200	203	Ø160	8 (M 16)
40 m <sup>3</sup> /h	80	16, 25	300	200	203	Ø160	8 (M 16)
60 m <sup>3</sup> /h	100	16	250	220	226	Ø180	8 (M 16)
60 m <sup>3</sup> /h	100	25	250	235	235	Ø190	8 (M 20)
60 m <sup>3</sup> /h	100	16	360	220	226	Ø180	8 (M 16)
60 m <sup>3</sup> /h	100	25	360	235	235	Ø190	8 (M 20)
100 m <sup>3</sup> /h	125	16	250	250	254	Ø210	8 (M 16)
100 m <sup>3</sup> /h	125	25	250	270	270	Ø220	8 (M 24)
150 m <sup>3</sup> /h	150	16	300	285	286	Ø240	8 (M 20)
150 m <sup>3</sup> /h	150	25	300	300	300	Ø250	8 (M 24)
150 m <sup>3</sup> /h	150	16	500	285	286	Ø240	8 (M 20)
150 m <sup>3</sup> /h	150	25	500	300	300	Ø250	8 (M 24)
250 m <sup>3</sup> /h	200	16	350	340	340	Ø295	12 (M 20)
250 m <sup>3</sup> /h	200	25	350	360	360	Ø310	12 (M 24)
400 m <sup>3</sup> /h	250	16	450	405	405	Ø355	12 (M 24)
400 m <sup>3</sup> /h	250	25	450	425	425	Ø370	12 (M 27)
800 m <sup>3</sup> /h	350	10	500	505	505	Ø460	16 (M 20)
800 m <sup>3</sup> /h	350	16	500	520	520	Ø470	16 (M 24)
1,500 m <sup>3</sup> /h	500	10	500	670	670	Ø620	20 (M 24)
1,500 m <sup>3</sup> /h	500	16	500	715	715	Ø650	20 (M 30)

Flanges according to standard DIN-EN 1092-1/DIN 2501/ISO 7005-1

## 13.4 Technical Data flow sensor Superstatic 440

qp	Threaded connection	Flanged connection	Length	Mat.	PN	Maximal flow qs	Minimal flow qi	Low flow threshold value (50°C)	Threaded hole for sensor	Weight (*) (**)	Kvs value (at 20°C)	Pressure loss at qp
m <sup>3</sup> /h	G"	DN	mm		PN	m <sup>3</sup> /h	l/h	l/h		kg	m <sup>3</sup> /h	bar
	(EN ISO 228-1)	(ISO 7005-3)										
1	3/4"	(15)	110	Brass	16/25	2	10	4	Yes	2,9	2,09	0,20
1	1"	(20)	190	Brass	16/25	2	10	4	Yes	3,2	2,09	0,20
1,5	3/4"	(15)	110	Brass	16/25	3	15	10	Yes	2,9	2,06	0,25
1,5	1"	(20)	190	Brass	16/25	3	15	10	Yes	3,2	5,44	0,09
2,5	1"	(20)	190	Brass	16/25	5	25	10	Yes	3,2	5,21	0,25
3,5	1 1/4"	(25)	260	Brass	16/25	7	35	15	Yes	3,5	7,46	0,16
3,5		25	260	Brass	16/25	7	35	15		5,4	7,46	0,16
6	1 1/4"	(25)	260	Brass	16/25	12	60	30	Yes	3,5	13,4	0,16
6		25	260	Brass	16/25	12	60	30		5,4	13,4	0,16
10	2"	(40)	300	Brass	16/25	20	100	50	Yes	4,5	20,9	0,25
10		40	300	Brass	16/25	20	100	50		8	20,9	0,25
		(ISO 7005-1)										
15		50	270	SS/CI	16/25	30	150	75		9,1	31,6	0,25
25		65	300	SS/CI	16/25	50	250	125		11,2	51,8	0,25
40		80	225	SS	16/25	80	800	400		14,4	142	0,09
40		80	300	SS/CI	16/25	80	800	400		13,1	142	0,09
60		100	250	SS	16/25	120	1,200	600		NA	210	0,10
60		100	360	SS/CI	16/25*	120	1,200	600		19	210	0,10
100		125	250	SS/CI	16/25*	200	2,000	1,000		NA	343	0,10
150		150	300	SS/CI	16/25*	300	3,000	1,500		27,2	514	0,10
150		150	500	SS	16/25	300	3,000	1,500		NA	514	0,10
250		200	350	SS	16/25	500	5,000	2,500		NA	857	0,10
400		250	450	SS	16/25	800	8,000	4,000		38,1	1,372	0,10

SS=Stainless Steel; CI=Spheroidal cast iron, \*: PN 25 only SS

(\*) Weight Value indicated only for the heaviest material.

(\*\*) Weight corresponding only for the flowmeter with 3mts cable.

NA : not available

						m <sup>3</sup> /h	m <sup>3</sup> /h	m <sup>3</sup> /h				
800		350	500	Steel	10/16	1,600	32	16		90/105	2,667	0,10
1,500		500	500	Steel	10/16	3,000	60	30		130/195	5,000	0,10

Coated Steel

The flow sensor Superstatic 440 can be operated from 0.5 bar pipe pressure. To prevent cavitation the operating pressure with a flow sensor Superstatic 440 must follow the recommendation in the table below. The Superstatic 440 must not be exposed to pressures below ambient pressure.

Flow		Static pressure (bar)	
q	% qp	T= 80°C	T= 130°C
qi (qmin)	1	1.0	3.3
qp	100	15.	4.0
qs	200	3.0	6.0

## 13.5 Optional Communication Modules Overview

### NOTICE

**Safety and service marks relevant to calibration must not be damaged or removed!**

Otherwise the warranty of the device is void. User seals may only be removed by authorized persons for service purposes and must then be renewed.

**Electrostatic discharges can destroy the module!**

Avoid electrostatic discharges when installing and handling the Modbus module. Before touching the calculator or Modbus module, touch an earthed pipe to discharge yourself electrostatically (e.g. a cold or hot water pipe).



**Automatic module recognition**

Once the modules have been installed, they are automatically detected by the Supercal 5 I within 30 seconds.

Designation	Articles	Slot 1	Slot 2	Needs mains power supply
M-Bus module	SC5X00020	Yes	Yes	No
BACnet / ModBus Module	SC5X00021	Yes	Yes	Yes
Digital Inputs module	SC5X00030	Yes	Yes	Yes
Digital Outputs module	SC5X00031	Yes	Yes	Yes
Analog Output module 0- 24 mA 0- 10 V	SC5X00032	Yes	Yes	Yes

## 13.6 Software

Designation	Articles
Software for reading and writing parameters in Supercal 5 The link to download the software can be found on our Extranet <i>My Sontex</i> . Access is password protected. Please contact your local representative for more information.	Superprog Windows
Commissioning Software for Supercal 5	Superprog Android

# 14. Return of goods form

For the return of goods we ask you to fill out the following form. You can find the form on our web-site at <https://sontex.ch/wp-content/uploads/2019/10/sontex-product-return-form-en.pdf>



## Products return form

Customer : .....

.....

E-Mail : .....

Reference : ..... Date : .....

### Returned products

Type	
Quant.	
Id.-No	

### Reason for return

- Warranty Repair / Replacement
- Test / Recalibration
- Repair
- Disposal
- Claim
- .....

### Problem description

Warranty conditions: Please refer to our General Terms and Conditions

Shipment address: *Sontex SA  
Rue de la Gare 27  
2605 Sonceboz  
Switzerland*



## 15. Country List

### Asia:

Australia, China, India, Indonesia, Japan, Korea, Malaysia, Singapore, Thailand, Vietnam

### Europe:

Belgium, Denmark, Germany, Estonia, France, Greece, Netherlands, Ireland, Italy, Latvia, Lithuania, Austria, Poland, Romania, Switzerland, Serbia, Slovenia, Slovakia, Spain, Czech Republic, Turkey, Hungary, United Kingdom

### Middle East:

Egypt, Iraq, Jordan, Saudi Arabia, United Arab Emirates

### North America:

Canada, USA

### Africa:

South Africa

(Status 11/2018 – subject to changes)

Further information can be found on our website [www.sontex.ch/contact](http://www.sontex.ch/contact)

## 16. Declaration of Conformity



Sontex hereby declares that the Supercal 5 I complies with MID 2014/32/EU and RED 2014/53EU.

The full text of the EU Declaration of Conformity is available at the following Internet link:



## Technical support

For technical support contact your local Sontex agent or Sontex SA directly.

### Hotline Sontex:

support@sontex.ch

+41 32 488 30 04

Technical modifications subject to change without notice





